

# TKM COLLEGE OF ENGINEERING

(Government Aided and Autonomous)

celebrating 60 years of excellence



---

## COMPUTER SCIENCE AND ENGINEERING

**B. Tech Curriculum 2024  
&  
First & Second Semester Syllabus**

**THANGAL KUNJU MUSALIAR COLLEGE OF ENGINEERING**  
**(Government Aided and Autonomous)**  
**KOLLAM-691005, KERALA**  
Abstract

TKMCE- Academics- B.Tech Computer Science and Engineering Curriculum 2024 -  
orders issued

No: ACU3/624/2024

Date: 03/09 /2024

**Order**

Read:

1. Minutes of the V Academic Council Meeting held on 31/07/2024

The fifth Academic council meeting held on 31st July 2024, approved the B.Tech Computer Science and Engineering Curriculum 2024 (B.Tech admissions 2024 onwards till the next revision). The academic curriculum for the B.Tech Computer Science Engineering programmes, 2024 approved by the Academic Council, is hereby notified as the **TKM College of Engineering (Aided and Autonomous) B.Tech Computer Science and Engineering Curriculum 2024.**

Orders are issued accordingly



  
PRINCIPAL IN-CHARGE  
THANGAL KUNJU MUSALIAR  
COLLEGE OF ENGINEERING  
KOLLAM - 691 005

Copy to: All HODs, Deans, IQAC, COE, AA, AO, SS, JS(A)

**THANGAL KUNJU MUSALIAR COLLEGE OF ENGINEERING**  
**(Government Aided and Autonomous)**  
**KOLLAM-691005, KERALA**  
Abstract

TKMCE- Academics- B.Tech S1 & S2 Computer Science and Engineering Syllabus  
2024 -orders issued

---

No: ACU3/631/2024

Date: 03/09 /2024

**Order**

---

Read:

1. Minutes of the V Academic Council Meeting held on 31/07/2024

The fifth Academic council meeting held on 31st July 2024, approved the B.Tech Computer Science and Engineering First Year (S1& S2 semester ) syllabus to be followed for the academic year 2024-25 onwards till the next revision .

Orders are issued accordingly

  
PRINCIPAL IN-CHARGE  
THANGAL KUNJU MUSALIAR  
COLLEGE OF ENGINEERING  
KOLLAM - 691 005

Copy to: All HODs, Deans, IQAC, COE, AA, AO, SS, JS(A)

## Preface to the Curriculum

The new undergraduate curriculum of TKM College of Engineering is designed to provide students with the skills and knowledge they need to become competent engineers capable of tackling real-world problems in a variety of fields. The curriculum is carefully designed to expose students to both theoretical and practical aspects of engineering and provide them with hands-on experience in the latest technologies and tools used in the industry. The courses given in the curriculum are tailored in a student centric fashion to ensure that they receive well-rounded education with the flexibility to customize their own learning experience according to their interests and career goals.

The allocation of 170 credits, of which 167 are from courses and 3 from activity points, over a period of four years, with each year comprising of two semesters. All courses in the curriculum are designed to highlight the significance of applying knowledge to engineering and technology challenges, fostering creativity, innovation, and developing entrepreneurial capabilities.

The curriculum includes project-based courses that emphasize hands-on learning and real-world applications supported by the fundamentals of engineering. These courses are offered with lab components, which allow students to gain practical experience in applying the concepts that they have learned. Additionally, there are basic science courses with lab components, core courses without practical components and lab courses to provide breadth wise knowledge in the area of recent technological trends. These variety of courses ensure that students receive a well-rounded education. They also get the flexibility to customize their own learning experience according to their interests and career goals. In addition to the core courses, students have the opportunity to choose from a wide range of elective courses in specialized areas.

The industry internship included in the curriculum will give students the opportunity to apply their theoretical knowledge to practical situations and expand their industrial knowledge. The students can opt for MOOC courses corresponding to Professional Elective and Open Elective Courses during their 7<sup>th</sup> and 8<sup>th</sup> semesters, which will give them opportunity for doing internships.

Moreover, the extracurricular activities that students can participate in to earn activity points will provide them with a well-versed education and help them develop important skills such as leadership, teamwork, and communication. This is a great initiative to ensure that students not only excel academically but also develop important life skills that will help them in their future endeavours.

## GENERAL COURSE STRUCTURE

### 1. Credit and Courses:

Classification	Credit assigned
1 Hour Lecture [L] per week	1 Credit
1 Hour Tutorial [T]per week	1 Credit
1 Hour Project [J] per week	1 Credit
2 Hours Practice/Practical [P] per week	1 Credit

Credits are a unit of measurement for course work and are based on the number of hours of instruction required per week. One hour of classroom lecture (L) that is 60 minutes long per week, is considered as one Instructional Unit or one Credit. The same goes for a tutorial (T) or a project (J) that is 60 minutes long per week.

In addition, a minimum of 2hours per week of laboratory session, practical or field work, training (P) or a combination of these, carried out during all weeks of the semester, is also considered one Instructional Unit or one Credit.

### Credit pattern

The B.Tech. program curriculum has a total of 167 academic credits and 3 additional pass/fail credits that can be gained through 100 activity points. The program will accommodate courses

from other disciplines also, so that students have multi-disciplinary exposure. Additionally, the program provides sufficient opportunities for students to enhance their communication, soft skills and managerial skills, along with technical skills. Depending on the program, the courses fall under engineering, basic science, humanities science, and management categories. The structure of the UG program essentially have the following categories of courses with the breakup of credits as given below:

Sl No:	Category	Code	Credit Breakup
1	Humanities and Social Sciences including Management courses	HSMC	16
2	Basic Science courses	BSC	22
3	Engineering Science courses including workshop, drawing, basics of electrical/ mechanical/computer etc.	ESC	27
4	Professional Core Courses	PCC	59
5	Professional Elective courses relevant to chosen specialization/ branch	PEC [MS]	[IEC] 12
6	Open Electives – Electives from other technical and /or emerging areas	OEC	
7	Major Project, seminar and internship in industry or elsewhere	PROJ	17
8	Mandatory Courses	MC	5
9	Mandatory Student Activities	SA	3
Total Credit			<b>170</b>
<b>Optional Specialization</b>			
10	Honors	HR	20
11	Minor	MR	20
Total credits with optional specialization			<b>190</b>

10 to 15 % deviation in credits is permitted under each discipline. While developing the curriculum, the department offering the program should ensure that the above distribution shall be attained by the students upon their completion of their program. Either Minor or Honors can be opted from the optional specialization.

The courses are organized into 1/2/3/4/5/6/14 credit courses based on the content delivery mechanism and desired depth of the course. The delivery methods include Theory-only, Theory with tutorial, Theory with practice, Theory with project etc. The L-T-P-J notation for each course signifies the allocation of hours for content delivery in terms of Lecture (L), Tutorial (T), Practical (P), and Project (J) per week, as well as the credit earned from the course. Apart from lecture, tutorial, practical/practice and the project hours, the curriculum offers Self learning hours(S) that indicates the number of hours students are expected to spent for activities outside the class defined by the faculty handling courses, and for the activities that support learning, initiated by the students themselves without the guidance from the faculty concerned. For each course, Self-learning hours per week is calculated as:

$$S = (L*1 + T*0 + P*1 + [J/2])$$

where J belongs to the project component of a project-based course. Thus, the L-T-P-J-S-C for each course indicates the number of hours scheduled as Lecture (L), Tutorial (T), Practical (P), Project (J), Self-study hours (S) and the total instructional delivery indicated as Credits (C).

$$C = L + T + [P/2] + J$$

For mandatory courses, irrespective of number of hours allotted in L-T-P-J the credit assigned will be 1.

Sl No.	Lecture-Tutorial-Practical/ Project [L-T-P-J]	Self-learning hours[S]	Credit [C]	Description
1	1-0-0-0	1	1	Theory course without End Semester Examination [ESE]
2	2-0-0-0	2	2	
3	2-0-2-0	4	3	Theory course integrated with practical
4	2-2-0-0	2	4	Theory course with tutorial
5	2-1-0-0	2	3	
6	3-1-0-0	3	4	
7	3-0-0-0	3	3	Theory course
8	3-1-2-0	5	5	Theory course integrated with practical and tutorial
9	2-1-2-0	4	4	
10	1-0-2-0	3	2	Theory course integrated with practical without ESE
11	3-0-2-0	5	4	Theory course integrated with practical
12	2-0-2-2	5	5	Project based course
13	0-0-2-0	2	1	Practical course without ESE
14	0-0-4-0	4	2	Practical course without ESE
15	0-0-6-0	6	3	Seminar
16	0-0-14-0	12	7	Major Project
<b>Mandatory Courses with 1 credit</b>				
17	2-0-0-0	2	1*	Theory Courses
	3-0-0-0	3		
18	2-0-2-0	4	1*	Theory course integrated with lab
19	0-0-0-2	1	1*	Socially Relevant Project
<b>Minor/ Honors Course</b>				
20	4-0-0-0	4	4	Theory course
21	0-0-0-4	2	4	Project only course

\*Credit for Mandatory Courses

### Course Category:

In general, the curriculum of each program consists of courses that are categorised into different heads such as Program Core (PCC), Professional Elective (PEC), Project-based courses (PBC), and Open Elective courses (OEC). The details of such courses are given below.

#### Program Core (PCC) or Professional Core

Program or Professional Core (PCC) courses are program-specific and are typically designed to provide students with a strong foundation in the core concepts and skills of their chosen field of study. By completing the PCC courses, students will have a solid understanding of the fundamental principles and practices in their field, which will prepare them for more advanced coursework and professional work in the future.

#### Project Based Course (PBC):

Project-based courses (PBC) are designed to provide students with a deeper knowledge and understanding of real-world challenges and problems in their field of study. Through PBC courses, students have the opportunity to actively explore and apply theoretical knowledge to real-world problems. This can help them develop problem-solving skills and gain practical experience that will be valuable in their future careers. Doing multiple projects can also help students develop a

range of skills that include project management, teamwork, communication and presentation skills.

#### Professional Elective (PEC):

Professional Elective (PEC) courses are designed to provide students with an opportunity to study more advanced, applied, or specialized courses than the basic courses they study as part of their program or professional core courses. PEC courses can help students gain in-depth knowledge of a specific sub-field. These courses are typically more focused and specialized than program core courses, and can help students develop expertise in a particular area in their discipline.

PEC courses provide students with the flexibility to tailor their education to their interests and career goals.

#### Micro specialization:

Electives can be streamlined to certain sub-disciplines of the B.Tech program, which are sometimes referred to as micro-specializations. This allows students to graduate with different micro-specializations by selecting a set of professional elective courses that are aligned with industry requirements or higher studies. A micro-specialization can be acquired by opting any two theory courses from the list of professional electives which is in line with a Program Core Course.

#### Open Elective courses (OEC):

Open Electives are courses that students need to study in other discipline alongside their primary area of study. These courses are designed to give students greater flexibility over their curriculum, allowing them to pursue their interests and passions. Open Electives promote cross-disciplinary and multidisciplinary learning. Students have the freedom to choose suitable courses from different streams. This can be a great way to broaden the knowledge and skills and to explore new areas of interest.

#### Seminar

Seminars are given to provide opportunity for students to make technical presentation on their research or ideas on a specific topic, to a peer audience. Seminars can be used to enhance students' communication skills, critical thinking skills, and ability to synthesize information from technical publications. It can be also used to encourage students to read and collect recent and reliable information from technical publications including peer-reviewed journals, conference papers, books, project reports, and other sources. The purpose of seminars is to create a learning environment where students can engage in active discussions and develop their presentation skills. Participating in seminars, students can gain valuable experience and develop the skills they need to succeed in their future careers.

#### Major Project:

Every student need to complete major project that spans through 7<sup>th</sup> and 8<sup>th</sup> semester. The project in the seventh semester shall be continued as the project in the eighth semester.

Minor and Honours courses: The Minor in Engineering program allows students to obtain degree in another domain. They also get interdisciplinary experience and exposure to concepts and perspectives.

- The student should earn additional 20 credits to be eligible for the award of B. Tech Degree with Minor.
- Out of the 20 credits, 12 credits should be earned by undergoing a minimum of three courses, of which one course shall be a mini project based on the chosen area.
- The remaining 8 credits could also be acquired through 2 MOOCs.

This program gives a great opportunity for students to broaden their understanding of the engineering profession.

#### Honors

Honors is intended for a student to gain advanced knowledge in an area with their B.Tech discipline in emerging/advanced areas in the branch of engineering concerned. Upon completion of Honors, a student will be better equipped to perform research in their branch of engineering.

- The student should earn additional 20 credits to be eligible for the award of B. Tech Degree with Honors.

- Out of the 20 credits, 12 credits should be earned by undergoing a minimum of three courses, of which one course should be a mini project based on the chosen specific area.
- The remaining 8 credits could be acquired through 2 MOOCs

#### Activity points:

To qualify for a B. Tech degree, all students are required to earn 100 activity points from various activity segments listed by the institution. These activity points are awarded on a pass/fail basis and are mandatory for obtaining the degree. While these activity points carry three credits, no grade is given for these credits, and they are not included in the calculation of the CGPA. The purpose of these activity points is to encourage students to participate in various extracurricular activities, such as sports, cultural events, and community service. For lateral entry students who join from the third semester, the activity point requirement is reduced to 75. The points earned by the student will be indicated in the consolidated academic statement, which is a record of the student's academic performance during their program.

The activity points can be earned by undertaking activities from different categories. Some of the categories are:

- (i) Internship
- (ii) MOOC/GRE/ TOEFL /GATE/ IELTS/MAT/SAT/CAT etc/ Foreign language proficiency
- (iii) Participation and organization of Co-curricular activities, Extracurricular activities.

Detailed list of activities and the related points are published along with the curriculum.

#### **Socially Relevant Projects**

The main purpose of Socially Relevant Projects is to connect the students with the society for mutual benefit. The community will benefit from the focused contribution of students towards local development. At the same time, the institution finds an opportunity to develop social sensibility and responsibility among students.

The objectives of Socially Relevant Projects are:

- ✓ To provide students with an opportunity to engage in meaningful community service and apply their learning to real-world situations.
- ✓ To promote civic responsibility and leadership skills among students, and to foster a deeper understanding of social issues.
- ✓ To facilitate the development of partnerships between colleges and local communities, and to contribute to local development.
- ✓ To encourage students to think critically and creatively about social issues, and to develop innovative solutions to address them.
- ✓ To promote interdisciplinary learning and collaboration, and to provide opportunities for students to apply their knowledge and skills across different fields.

#### **Activities for Socially Relevant Project**

- ❖ Conducting surveys and research on social issues and concerns to gain a better understanding of the problem and identify potential solutions.
- ❖ Developing and implementing educational programs to promote awareness and understanding of social issues and concerns.
- ❖ Collaborating with local NGOs and community groups to organize events and activities that promote social welfare and community development.
- ❖ Developing and implementing social welfare programs that address the needs of marginalized and vulnerable communities, such as homeless individuals, refugees, and low-income families.
- ❖ Conducting community service activities, such as volunteering at local shelters, food banks, and community centers.
- ❖ Developing and implementing environmental conservation programs that promote sustainable practices and reduce the impact of human activities on the environment.
- ❖ Creating and distributing educational materials, such as pamphlets and brochures, to raise awareness about social issues and concerns.



- ❖ Organizing fundraising events to support social welfare programs and community development initiatives.
- ❖ Engaging in advocacy and lobbying efforts to influence public policy and promote social justice.

#### Procedure for doing Socially Relevant Project

- ❖ Assign a group of students or a single student to a particular habitation, village, or municipal ward in the near vicinity of their place of stay.
- ❖ Conduct a survey of the habitation to gain a better understanding of the social issues and concerns that need to be addressed. A common survey format could be designed to ensure consistency.
- ❖ Develop a project work related to the student's domain or subject area that addresses the identified social issues and concerns. The project should be designed to be socially relevant and have a positive impact on the community.
- ❖ Implement the project work with the help of the local community and relevant authorities. This could include organizing awareness programs, developing and implementing educational programs, conducting community service activities, and engaging in advocacy and lobbying efforts.
- ❖ Monitor and evaluate the project work to ensure that it is having the desired impact on the community. This could include conducting surveys and research, gathering feedback from the local community, and tracking key performance indicators.
- ❖ Document the project work and its impact on the community, and share the findings with relevant stakeholders, including the local community, government authorities, and academic institutions

#### **Internships**

Internships offer students an excellent opportunity to gain industry exposure and prepare for their future work environment. All B.Tech students shall complete a minimum of six to eight weeks of internship in any reputed industry, research organization, or another esteemed institute of higher learning. This requirement can be fulfilled any time after their first year of study and before the seventh semester. The training can be undertaken in a single stretch or in segments, with each segment lasting at least two weeks. Students should select the organization for their internship in consultation with their senior faculty advisor. Additionally, the curriculum provides the option to undertake full-semester internship in the 7th or 8th semester.

#### **Structure of Course code:**

Each course will be identified by a unique Course Code consisting of eight alpha numeric characters (Two digits, three alphabets which together followed by three digits) and is represented as **YYXXCSNN**, which can be interpreted as: YY – Regulation Year XX - Stream Code C- Course Delivery Mode, S – Semester Number (it can have a number from 1 to 8) NN- Course Sequence Number

For eg: 24CET303- is a theory course offered by the civil engineering department in the third semester of the 2024 scheme.

24MEL408 - is a laboratory course offered by the mechanical engineering department in the fourth semester of the 2024 scheme.

24CSP607 - - is a laboratory course offered by the computer science department in the sixth semester of 2024 scheme.

Year of Regulation YY	Course category XX	Course delivery mode C	Semester Number S	Serial No. of course NN
24 for 2024 regulation	BY -BIOLOGY	T - THEORY ALONE	1	01
	CE - CIVIL ENGINEERING	P - THEORY INTEGRATED WITH PRACTICAL COURSE	2 3 etc.	02 03 etc.
	CH - CHEMICAL ENGINEERING	L-LABORATORY COURSE		
	CS - COMPUTER SCIENCE &ENGINEERING	J - THEORY NTEGERATED WITH PROJECT (PROJECT BASED COURSE)		
	CY – CHEMISTRY	E – PROFESSIONAL ELECTIVE COURSE		
	EC- ELECTRONICS & COMMUNICATION ENGINEERING	O - OPEN ELECTIVE COURSE		
	EE – ELECTRICAL & ELECTRONICS ENGINEERING	H - HONORS COURSE		
	ER – ELECTRICAL & COMPUTER ENGINEERING	M - MINOR COURSE		
	AI – COMPUTER SCIENCE & ENGINEERING[AI]	S - SEMINAR		
	ES - ENGINEERING SCIENCE COURSE	R - RESEARCH BASED MINI PROJECT		
	HU - HUMANITY, SOCIAL SCIENCE AND MANAGEMENT	D - PROJECT		
	MA - MATHEMATICS	N - INTERNSHIP		
	MC- MANDATORY COURSE			
	ME - MECHANICAL ENGINEERING			
	PY – PHYSICS			

### Assessment

In each semester, students shall be evaluated both by Continuous Internal Assessment (CIA) and End Semester Examinations (ESE) or by Continuous Internal Assessment alone based on the credit assigned to the course. The Continuous Internal assessment shall be on the basis of the day-to-day work, periodic tests, assignments, quizzes, presentations and other suitable tools

devised by the faculty. The faculty member(s) concerned should carry out the CIA for the courses allotted to them in the following perspectives with respect to all courses:

- Evaluation with respect to knowledge
- Evaluation with respect to Understanding
- Evaluation with respect to skill
- Evaluation with respect to Applications and/or
- Higher Order Thinking Skills

For the Practice part of a course or a pure Practice (Laboratory/Practical) course; due weightage shall be given for carrying out experiments, observations, collection of data, analysis, interpretation of results, inference etc. Timely submission of record work shall also carry due weightage based on the type of laboratories and the course. The CIA marks for individual courses shall be computed by giving weightage to the parameters given in the table below.

<b>Mark Distribution of CIA</b>										
<b>Course Structure [L-T-P-J]</b>	<b>Attendance</b>	<b>Theory [L- T]</b>				<b>Practical [P]</b>		<b>Project [J]</b>		<b>Total Marks</b>
		<b>Assignment</b>	<b>Test-1</b>	<b>Test-2</b>	<b>#Class work</b>	<b>Lab Exam</b>	<b>Evaluation 1</b>	<b>Evaluation-2</b>	<b>Report</b>	
<b>1-0-0-0</b>	5	25	20	-	-	-	-	-	-	<b>50</b>
<b>2-0-0-0</b>	5	35	30	30	-	-	-	-	-	<b>100</b>
<b>1-0-2-0</b>	5	10	20	-	25	40	-	-	-	<b>100</b>
<b>0-0-2-0</b>	5	-	-	-	35	10	-	-	-	<b>50</b>
<b>0-0-4-0</b>	5	-	-	-	25	30	-	-	-	<b>60</b>
<b>2-1-0-0</b>	5	15	10	10	-	-	-	-	-	<b>40</b>
<b>3-0-0-0</b>	5	15	10	10	-	-	-	-	-	<b>40</b>
<b>3-1-0-0</b>	5	15	10	10	-	-	-	-	-	<b>40</b>
<b>4-0-0-0</b>	5	15	10	10	-	-	-	-	-	<b>40</b>
<b>2-0-2-0</b>	5	10	-	15	15	15	-	-	-	<b>60</b>
<b>3-1-2-0</b>	5	10	12.5	12.5	10	10				<b>60</b>
<b>2-1-2-0</b>	5	10	12.5	12.5	10	10	-	-	-	<b>60</b>
<b>3-0-2-0</b>	5	10	12.5	12.5	10	10	-	-	-	<b>60</b>
<b>2-0-2-2</b>	5	10	-	15	10		5	10	5	<b>60</b>
<b>2-2-0-0</b>	5	10	12.5	12.5						<b>40</b>
<b>^2-0-2-0</b>	5	10	20		*45	20				<b>100</b>
<b>&amp;0-0-4-0</b>	5				55	40				<b>100</b>

^ For Idea lab only, & For Manufacturing Practices only \*Split up is given in the syllabus

#### **Assessment of Assignment component of CIA**

Based on the course category the number of assignments that shall be given for each course may vary. The table given below gives the details about it.

Course Category	L-T-P-J	Credit	Assessment of Assignment component of CIA
Theory Course	1-0-0-0	1	One assessment per two and half module
	2-0-0-0	2	
Theory Embedded with Practical	1-0-2-0	2	
Theory Course	2-1-0-0	3	Minimum two assessments per two and half modules. If more numbers are given, best two shall be considered for the calculation of CIA.
	2-2-0-0	4	
	3-0-0-0	3	
	3-1-0-0	4	
	4-0-0-0	4	
Theory Embedded with Practical	2-0-2-0	3	
	3-1-2-0	5	
	2-1-2-0	4	
	3-0-2-0	4	
Project Based Course	2-0-2-2	5	

### Evaluation Type, CIA & ESE Mark Distribution:

The evaluation type, CIA & ESE mark distribution for courses with various course structures are given in the following table:

Evaluation Type	Course Category	L-T-P-J	Credit	CIA Mark	ESE Mark	CIA %	ESE %
CIA only	Theory Course	1-0-0-0	1	50	-	100%	-
		2-0-0-0	2	100			
	Theory integrated with Practical	1-0-2-0	2				
	Practical	0-0-2-0	1	50			
		0-0-4-0	2	100			
	Seminar	0-0-6-0	3				
	Project [Minor/Honor]	0-0-0-4	4				
Major Project	0-0-14-0	7					
CIA + ESE	Theory Course	2-1-0-0	3	40	60	40%	60%
		2-2-0-0	4				
		3-0-0-0	3				
		3-1-0-0	4				
		4-0-0-0	4				
	Theory integrated with Practical	2-0-2-0	3	60	40	60%	40%
		3-1-2-0	5				
		2-1-2-0	4				
		3-0-2-0	4				
	Project Based Course	2-0-2-2	5				

### Evaluation pattern for End Semester Examination

The end-semester examination shall have the learning assessments from the following perspectives for all courses:

- Evaluation with respect to Knowledge
- Evaluation with respect to Understanding
- Evaluation with respect to Applications

Separate evaluation pattern shall be followed for ESE, as given in table below.

<b>PATTERN</b>	<b>PART A</b>	<b>PART B</b>	<b>ESE Marks</b>
PATTERN 1	10 Questions, each question carries 2 marks Marks: (2x10 =20 marks)	2 questions will be given from each module, out of which 1 question should be answered. Each question can have a maximum of 2 sub divisions. Each question carries 8 marks. Marks: (5x8 = 40 marks) Time: 3 hours	<b>60</b>
	Total Marks: 20	Total Marks: [5x8 = 40 marks]	
PATTERN 2	NIL	2 questions will be given from each module, out of which 1 question should be answered. Each question can have a maximum of 2 sub divisions. Each question carries 8 marks. Marks: (5x 8 = 40 marks) Time: 2.5 hours	<b>40</b>
	Total Marks: 0	Total Marks: [5x8 = 40 marks]	
PATTERN 3 [For the course 24EST108/24EST206 Engineering Graphics 2-2-0-0	NIL	2 questions will be given from each module, out of which 1 question should be answered. Each question carries 12 marks. Marks: (5x 12 = 60 marks) Time: 3 hours	<b>60</b>
	Total Marks: 0	Total Marks: [5x12 = 60 marks]	
PATTERN 4 (For the course 24CHP701 Computer-Aided Process Design (2-1-2-0)	NIL	2 Questions, each question carries 40 marks. Each question can have a maximum of 2 sub-divisions. Marks: (1x40 = 40 marks) Time: 2.5 hours	<b>40</b>
	Total Marks: 0	Total Marks: (1x40 = 40 marks]	

The condition for passing a course shall be 40% for the End Semester Examination, 40% of CIA, and 50% for CIA and ESE put together. Letter grade 'F' will be awarded to the student for a course if either their marks for the ESE is below 40 % or mark for the CIA is below 40 % or the overall mark [Continuous Internal Evaluation + End Semester Examination] is below 50 %. For courses with only CIA [having no ESE], a minimum of 50% of CIA mark is required for passing.

### **Grade and Grade point**

Grading is based on the overall percentage marks obtained by the student in a course. The grade card shows the grades obtained for the courses the student has registered. Semester grade card gives the grade for each registered course, Semester Grade Point Average (SGPA) for the semester as well as Cumulative Grade Point Average (CGPA). The details of assigning Grades and the corresponding Grade point are given in the table below.

Grades	Grade Point [GP]	% of Total Marks obtained
S	10	90% and above
A+	9.0	85% and above but less than 90%
A	8.5	80% and above but less than 85%
B+	8	75% and above but less than 80%
B	7.5	70% and above but less than 75%
C+	7.0	65% and above but less than 70%
C	6.5	60% and above but less than 65%
D	6	55% and above but less than 60%
P [Pass]	5.5	50% and above but less than 55%
F [Fail]	0	Below 50% (CIA + ESE) or Below 40 % for ESE Below 40 % for CIA Below 50% for courses with only CIA and no ESE
FE	0	Failed due to lack of eligibility criteria
I	0	Could not appear for the end semester examination but fulfils the eligibility criteria.
First Class with Distinction		CGPA 8.0 and above
First Class		CGPA 6.5 and above
Equivalent percentage mark shall be = 10 * CGPA		

### Allotted and Cumulative Credits

The allotted and cumulative credits of circuit and non- circuit branches are given in table below

Semester	Circuit branches [CS, EC, EE, ER & AI]		Non-Circuit branches [CE, ME &CH]	
	Allotted Credits	Cumulative Credits	Allotted Credits	Cumulative Credits
First	20	-	23	-
Second	23	43	21	44
Third	24	67	23	67
Fourth	22	89	22	89
Fifth	21	110	21	110
Sixth	20	130	20	130
Seventh	21	151	21	151
Eighth	16	167	16	167

**Circuit branches:** Computer Science & Engineering [CS], Computer Science & Engineering [AI], Electronics & Communication [EC], Electrical & Electronics [ER] and Electrical & Computer Science [ER]

**Non-Circuit branches:** Civil [CE], Mechanical [ME] and Chemical Engineering [CH]

## **CURRICULUM**

DEPARTMENT OF COMPUTER SCIENCE & ENGINEERING

FIRST SEMESTER													
SI No	Slot	Code	Category	Title	L	T	P	J	S	No. of Hours	No. of Credits	Total Marks	
												CIA	ESE
1	A	24MAT101	BSC	Calculus and Linear Algebra	3	1	0	0	3	4	4	40	60
2	B	24PYP102	BSC	Engineering Physics	2	1	2	0	4	5	4	60	40
3	C	24EST104	ESC	Fundamentals of Electrical Engineering	3	0	0	0	3	3	3	40	60
4	D	24ESP107	ESC	Technical English for Engineers	2	0	2	0	4	4	3	60	40
5	E	24MCP110	MC	IDEA Lab	2	0	2	0	4	4	1	100	
6	F	24HUL111	HSMC	Design Thinking	0	0	2	0	2	2	1	50	
7	I	24CST105	PCC	Logic System Design	2	0	0	0	2	2	2	100	
8	J1	24ESL106	ESC	Introduction to Programming Frameworks	0	0	2	0	2	2	1	50	
9	J2	24ESL107	ESC	Application development Lab	0	0	2	0	2	2	1	50	
									<b>26</b>	<b>28</b>	<b>20</b>		
SECOND SEMESTER													
SI No	Slot	Code	Category	Title	L	T	P	J	S	No. of Hours	No. of Credits	Total Marks	
												CIA	ESE
1	A	24MAP200	BSC	Ordinary Differential Equations and Transforms	3	1	2	0	5	6	5	60	40
2	B	24CYP203	BSC	Engineering Chemistry	2	1	2	0	4	5	4	60	40
3	C	24ESP204	ESC	Problem solving and Programming	3	0	2	0	5	5	4	60	40
4	D	24EST206	ESC	Engineering Graphics	2	2	0	0	4	4	4	40	60
5	G	24ESL207	ESC	Manufacturing Practices	0	0	4	0	4	4	2	100	
6	K	24MCT210	MC	Sports and Wellness	2	0	0	0	2	2	1	100	
7	E	24HUT211	HSMC	Universal Human Values-II	2	1	0	0	3	3	3	40	60
									<b>27</b>	<b>29</b>	<b>23</b>		



THIRD SEMESTER													
SI No	Slot	Code	Category	Title	L	T	P	J	S	No. of Hours	No. of Credits	Total Marks	
												CIA	ESE
1	A	24MAP301	BSC	Advanced Linear Algebra, Complex Analysis and Partial Differential Equations	3	1	2	0	5	6	5	60	40
2	K	24EST352	ESC	Probability, Statistics and Optimization	2	0	0	0	2	2	2	100	
3	B	24CSJ303	PBC	Advanced Programming	2	0	2	2	5	6	5	60	40
4	C	24CSP304	PCC	Data Structures and Algorithms	2	1	2	0	4	5	4	60	40
5	D	24CSP305	PCC	Computer Organization and Architecture	2	1	2	0	4	5	4	60	40
6	E	24HUT310	HSMC	Life Skills and Professional Ethics	3	0	0	0	3	3	3	40	60
7	I	24EST322	ESC	Basic Engineering Mechanics	2	0	0	0	2	2	2	100	
8	M/R	24CSM3XX	MR/RL	MINOR/REMEDIAL	4	0	0	0			4/0	40	60
									25	29	25		
FOURTH SEMESTER													
SI No	Slot	Code	Category	Title	L	T	P	J	S	No. of Hours	No. of Credits	Total Marks	
												CIA	ESE
1	A	24CST401	PCC	Discrete Mathematics	2	1	0	0	2	3	3	40	60
2	B	24CSP402	PCC	Computer Networks	2	1	2	0	4	5	4	60	40
3	C	24CSP403	PCC	Operating Systems	2	1	2	0	4	5	4	60	40
4	D	24CSJ404	PBC	Introduction to Database Systems	2	0	2	2	5	6	5	60	40
5	E	24HUT455	HSMC	Management-I (Organizational Behavior)	3	0	0	0	3	3	3	40	60
6	F	24MCT406	MC	Environmental Sciences	3	0	0	0	3	3	1	40	60
7	I	24BYT407	ESC	Biology for Engineers	2	0	0	0	2	2	2	100	
8	M/H/R	24CSM4XX / 24CSH4XX	MR/HR/RL	MINOR/HONORS/REMEDIAL	4	0	0	0			4/4/0	40	60
									23	27	22		

FIFTH SEMESTER													
SI No	Slot	Code	Category	Title	L	T	P	J	S	No. of Hours	No. of Credits	Total Marks	
												CIA	ESE
1	A	24CST501	PCC	Design & Analysis of Algorithms	2	1	0	0	2	3	3	40	60
2	B	24CST502	PCC	Software Engineering	2	1	0	0	2	3	3	40	60
3	C	24CSP503	PCC	Artificial Intelligence & Machine Learning	2	1	2	0	4	5	4	60	40
4	D	24CSJ504	PBC	Advanced Web Technologies	2	0	2	2	5	6	5	60	40
5	E	24HUT555	HSMC	Finance and Accounting	3	0	0	0	3	3	3	40	60
6	F	24MCT506	MC	Constitution of India	MOOC				3		1		
7	I	24HUL507	HSMC	Technical writing	0	0	2	0	2	2	1	50	
8	J	24HUL508	HSMC	Soft Skills	0	0	2	0	2	2	1	50	
9	M/ H/ R	24CSM5XX / 24CSH5XX		MINOR/HONORS/REMEDIAL	4	0	0	0			4/4/0	40	60
									<b>23</b>	<b>24</b>	<b>21</b>		
SIXTH SEMESTER													
SI No	Slot	Code	Category	Title	L	T	P	J	S	No. of Hours	No. of Credits	Total Marks	
												CIA	ESE
1	A	24CST601	PCC	Theory of Computation	2	1	0	0	2	3	3	40	60
2	B	24CSP602	PCC	Introductory Cyber Security	2	0	2	0	4	4	3	60	40
3	C	24CSE6X4	PEC	Professional Elective I	3	0	0	0	3	3	3	40	60
4	D	24CSE6X5 / 24CSI6X5	PEC/ IEC	Professional Elective-2/ Industry Elective	3	0	0	0	3	3	3	40	60
5	F	24CSS606	SR	Seminar	0	0	4	0	4	4	2	100	
6	U	24SPJ607	MC	Socially Relevant Project	0	0	0	2	1	2	1	100	
7	I	24EST608	ESC	Digital Image Processing	2	0	0	0	2	2	2	100	
8	J	24HUT609	HSMC	Entrepreneurships and startups	2	0	0	0	2	2	2	100	
9	M/ H/ R	24CSM6XX / 24CSH6XX		MINOR/HONOURS/REMEDIAL	4	0	0	0			4/4/0	40	60
									<b>21</b>	<b>23</b>	<b>19</b>		

SEVENTH SEMESTER													
SI No	Slot	Code	Category	Title	L	T	P	J	S	No. of Hours	No. of Credits	Total Marks	
												CIA	ESE
1	A	24CSP701	PCC	Compiler Design (Internship Students: Online Classes with virtual lab)	2	1	2	0	4	5	4	60	40
2	B	24CSP702	PCC	Cloud Computing (Internship Students: Online Classes with virtual lab)	2	1	2	0	4	5	4	60	40
3	C	24CSE7X3	PEC	Professional Elective-3 (Internship Students: MOOC Approved by the Institute/Online Classes)	3	0	0	0	3	3	3	40	60
4	D	24CS07X4 / 24CSI7X4	OEC /IEC	Open Elective 1/ Industry Elective (Internship Students: MOOC Approved by the Institute/Online Classes)	3	0	0	0	3	3	3	40	60
5	U	24CSD705	PR	PROJECT/ INTERNSHIP Option 1: Major Project Option 2: Internship (4-6 Months)	0	0	1 4	0	14	14	7	100	
6	M/ H/ R	24CSM709 / 24CSH7XX	PRM /HR /RL	PROJECT IN MINOR/HONORS/ REMEDIAL	0	0	0	4			4/4/ 0	100	
									<b>28</b>	<b>30</b>	<b>21</b>		
<p>The students have the option to undertake an internship either in the 7<sup>th</sup> or 8<sup>th</sup> semester. The students taking up the internship shall fulfil all the requirements of internal assessments such as series test, quizzes, assignments etc.</p> <p>* Option 1: Work on a project within the institute or department under the mentorship of faculty members.</p> <p>* Option 2: Complete a full-semester internship in an industry or organization.</p>													

EIGHTH SEMESTER													
SI No	Slot	Code	Category	Title	L	T	P	J	S	No. of Hours	No. of Credits	Total Marks	
												CIA	ESE
1	A	24CSE8X1	PEC	Professional Elective-4 / MOOC (Internship Students: MOOC Approved by the Institute/Online Classes)	3	0	0	0	3	3	3	40	60
2	B	24CSO8X2	OEC	Open Elective-2/ MOOC (Internship Students: MOOC Approved by the Institute/Online Classes)	3	0	0	0	3	3	3	40	60
3	C	24CSO8X3	OEC	Open Elective- 3/ MOOC (Internship Students: MOOC Approved by the Institute/Online Classes)	3	0	0	0	3	3	3	40	60
4	U	24CSD804 / 24CSN804	PR/ IP	PROJECT/ INTERNSHIP Option 2: Internship (4-6 Months) for the students who have done Major Project in the 7 <sup>th</sup> semester	0	0	1 4	0	14	14	7	100	
5	H	24CSH809	PRH	PROJECT IN HONORS	0	0	0	4			4	100	
									<b>23</b>	<b>23</b>	<b>16</b>		

The students taking up the internship shall fulfil all the requirements of internal assessments such as series test, quizzes, assignments etc.

## **Professional Electives (PE)**

### **Professional Elective 1**

<b>Slot</b>	<b>Course Code</b>	<b>Course Name</b>
C	24CSE614	Advanced Machine Learning
	24CSE624	Wireless Sensor Networks
	24CSE634	Agile Methodologies*
	24CSE644	Advanced Algorithms
	24CSE654	Data Mining
	24CSE664	Distributed Computing
	24CSE674	Advanced Data Base System*
	24CSE684	Object Oriented System Design*
	24CSE694	Information Security
	24CSE6104	Mobile And Wireless Security
	24CSE6114	Advanced Computer Architecture
	24CSE6124	Data Storage Technologies And Networks
	24CSE6134	Medical Imaging
	24CSE6144	Information Retrieval
	24CSE6154	Fuzzy Logic And Its Application
24CSE6164	Computer Graphics	

### **Professional Elective 2/Industry Elective**

<b>Slot</b>	<b>Course Code</b>	<b>Course Name</b>
D	24CSE615	Natural Language Processing
	24CSE625	Mobile Computing
	24CSE635	Parallel Algorithms
	24CSE645	Bioinformatics
	24CSE655	Principles of Programming Languages
	24CSE665	Secure Coding
	24CSE675	Social Networking And Security

	24CSE685	High Performance Computing
	24CSE695	IoT and Embedded Systems
	24CSE6105	Neural Networks And Deep Learning
	24CSE6115	Neural Networks And Fuzzy Logic
	24CSE6125	Internet of Things
	24CSE6135	Remote Sensing And Applications
	24CSE6145	Medical Imaging
	24CSI615	Software Testing*
	24CSI625	Blockchain Technology*

### **Professional Elective 3**

<b>Slot</b>	<b>Course Code</b>	<b>Course Name</b>
C	24CSE713	Speech Processing
	24CSE723	Wireless and Mobile Communications
	24CSE733	Software Reliability*
	24CSE743	Evolutionary algorithms
	24CSE753	Parallel and Distributed Algorithms
	24CSE763	Big Data Analytics*
	24CSE773	Web Mining
	24CSE783	Advanced Social, Text and Media Analytics
	24CSE793	Digital Currency Programming*
	24CSE7103	Android programming*
	24CSE7113	Networks and Systems Security
	24CSE7123	Ethical Hacking*
	24CSE7133	GPU Architecture and Programming
	24CSE7143	Software Defined networks
	24CSE7153	AWS Cloud Computing*
	24CSE7163	Soft Computing

### **Professional Elective 4**

Slot	Course Code	Course Name
A	24CSE811	Reinforcement Learning
	24CSE821	Explainable AI
	24CSE831	Mobile Adhoc Networks
	24CSE841	Total Quality Management*
	24CSE851	Software Project Management*
	24CSE861	Swarm Intelligence
	24CSE871	Social Network Analytics
	24CSE881	Time Series Analysis and Forecasting
	24CSE891	Quantum Computing
	24CSE8101	Data Compression
	24CSE8111	Cloud security
	24CSE8121	Cyber Forensics*
	24CSE8131	IoT Security
	24CSE8141	Introduction to Devops*
	24CSE8151	Augmented and Virtual Reality
24CSE8161	Human Computer Interaction	

\*Industry offered course

### Open Electives

#### Open Elective 1/ Industry Elective

Slot	Course Code	Course Name
D	24CSO714	Data Structures
	24CSO724	Introduction to Soft Computing
	24CSO734	Development of Mobile Apps
	24CSO744	E-Commerce
	24CSI714	Cyber Law & Ethics

#### Open Elective 2/MOOC

Slot	Course Code	Course Name
B	24CSO812	Computer Graphics

	24CSO822	Artificial Intelligence
	24CSO832	Python Programming
	24CSO842	Data Management and Analysis
	24CSO852	Mobile Computing

### **Open Elective 3/MOOC**

<b>Slot</b>	<b>Course Code</b>	<b>Course Name</b>
C	24CSO813	Machine Learning
	24CSO823	Scripting Languages
	24CSO833	Database Management Systems
	24CSO843	Computer Architecture
	24CSO853	Big Data Analytics

<b>MICRO SPECIALIZATION BUCKETS</b>					
<b>Bucket</b>	<b>Course 1</b>		<b>Course 2</b>		<b>Prerequisite Course</b>
	<b>Course Code</b>	<b>Course Name</b>	<b>Course Code</b>	<b>Course Name</b>	
Artificial Intelligence	24CSE615	Natural Language Processing	24CSE713	Speech Processing	Artificial Intelligence & Machine Learning
Machine Learning	24CSE614	Advanced Machine Learning	24CSE811	Reinforcement learning	
Interpretable AI	24CSE614	Advanced Machine Learning	24CSE821	Explainable AI	
Adhoc and Sensor Networks	24CSE624	Wireless Sensor Networks	24CSE831	Mobile Adhoc Networks	Computer Networks
Mobile and Wireless Communication	24CSE625	Mobile Computing	24CSE723	Wireless and Mobile Communications	
Internet of Things	24CSE6125	Internet of Things	24CSE8131	IoT Security	
Agile Software Engineering	24CSE634	Agile Methodologies	24CSE851	Software Project Management	Software Engineering
Advanced Software Engineering	24CSE733	Software Reliability	24CSE841	Total quality Management	
Software Reliability	24CSI615	Software Testing	24CSE733	Software Reliability	



Object Oriented Software Engineering	24CSE684	Object Oriented System Design	24CSE851	Software Project Management	
Advanced Algorithmic approaches	24CSE644	Advanced Algorithms	24CSE753	Parallel and Distributed Algorithms	Design and Analysis of Algorithms
Optimization Algorithms	24CSE743	Evolutionary algorithms	24CSE861	Swarm Intelligence	
Big Data Analytics	24CSE654	Data Mining	24CSE763	Big Data Analytics	Introduction to Database Systems
Advanced Data Mining	24CSE773	Web Mining	24CSE871	Social Network Analytics	
Data Mining and Forecasting	24CSE763	Big Data Analytics	24CSE881	Time Series Analysis and Forecasting	
Blockchain and Digital Currency technology	24CSI625	Blockchain technology	24CSE793	Digital Currency Programming	
Database and Digital Currency technology	24CSE674	Advanced Database system	24CSE793	Digital Currency Programming	
Information Security	24CSE7113	Networks and Systems Security	24CSE8111	Cloud Security	Introductory cyber security
Cyber Security	24CSE7123	Ethical Hacking	24CSE8121	Cyber Forensics	
Secure Programming	24CSE665	Secure Coding	24CSE7123	Ethical Hacking	Advanced Programming
Advanced Computer Architecture	24CSE6114	Advanced Computer Architecture	24CSE7133	GPU Architecture and Programming	Computer organization
Software Automation	24CSE7153	AWS Cloud Computing	24CSE8141	Introduction to Devops	Advanced Programming and Cloud Computing
Software Development and Deployment	24CSE634	Agile Methodologies	24CSE8141	Introduction to Devops	

**\*Industry offered course**

<b>MINOR BUCKETS</b>				
<b>SEMESTER</b>	<b>BUCKET 1</b>		<b>BUCKET 2</b>	
	<b>Specialization - Machine Learning</b>		<b>Specialization - Software Engineering*</b>	
	<b>Course Code</b>	<b>Course Name</b>	<b>Course Code</b>	<b>Course Name</b>
<b>S3</b>	24CSM309	Python for Machine Learning	24CSM310	Object Oriented Programming*
<b>S4</b>	24CSM409	Mathematics for Machine Learning	24CSM410	Software Engineering *
<b>S5</b>	24CSM509	Concepts in Machine Learning	24CSM510	Software Testing *
<b>S6</b>	24CSM609	Concepts in Deep Learning	24CSM610	Software Project Management*

<b>S7</b>	24CSM709	PROJECT IN MINOR	24CSM709	PROJECT IN MINOR
-----------	----------	------------------	----------	------------------

**\*Industry offered Course**

**HONORS BUCKETS**

<b>SEMESTER</b>	<b>BUCKET 1</b>		<b>BUCKET 2</b>		<b>BUCKET 3</b>	
	<b>Specialization - Data Structures and Algorithms</b>		<b>Specialization - Systems Engineering</b>		<b>Specialization - Data Science</b>	
	<b>Course Code</b>	<b>Course Name</b>	<b>Course Code</b>	<b>Course Name</b>	<b>Course Code</b>	<b>Course Name</b>
<b>S4</b>	24CSH409	Computational Geometry	24CSH410	System Software	24CSH411	Data and Web Mining
<b>S5</b>	24CSH509	Advanced Data structures and Algorithms	24CSH510	Advanced Operating Systems	24CSH511	Business Analytics
<b>S6</b>	24CSH609	Parallel Algorithms	24CSH610	Advanced Database Management Systems	24CSH611	Social Network Analytics
<b>S7</b>	24CSH709	Evolutionary Algorithms	24CSH710	Advanced Computer Architecture	24CSH711	Time Series Analysis and Forecasting
<b>S8</b>	24CSH809	Project in Honors	24CSH809	Project in Honors	24CSH809	Project in Honors

# SEMESTER I

24MAP101	CALCULUS and LINEAR ALGEBRA	L	T	P	J	S	C	Year of Introduction 2024
		3	1	0	0	3	4	

**Preamble:**

The course enables the students to understand basic concepts and tools of Calculus and Linear Algebra. The topics like Multivariable Calculus and Applications, Multiple integrals and applications, Vector Differentiation, Vector Integration and Linear Algebra are included. This course helps the learners in modeling and analyzing physical phenomena involving continuous changes of variables or parameters and has applications across all engineering domains.

**Prerequisite:** Calculus of univariate functions and matrix theory.

**Course Outcomes:** After the completion of the course the student will be able to

- CO 1** Apply the concept of partial derivatives to evaluate the extrema of two variable functions. [**Apply level**]
- CO 2** Use multiple integrals to find the area and volume of geometrical shapes, mass and center of gravity of plane laminas. [**Apply level**]
- CO 3** Utilize vector calculus techniques to solve problems related to vector fields in various disciplines. [**Apply level**]
- CO 4** Apply appropriate techniques such as Green's theorem, Stokes' theorem and divergence theorem to evaluate vector integrals for different types of regions and surfaces. [**Apply level**]
- CO 5** Use the Gauss elimination method to solve given systems of linear equations and to determine whether a matrix is diagonalizable. [**Apply level**]

**CO - PO MAPPING**

CO	PO1	PO2	PO3	PO4	PO5	PO6	PO7	PO8	PO9	PO10	PO11	PO12
CO 1	✓	✓			✓				✓			✓
CO 2	✓	✓			✓				✓			✓
CO 3	✓	✓			✓				✓			✓
CO 4	✓	✓			✓				✓			✓
CO 5	✓	✓			✓				✓			✓

**Assessment Pattern**

Bloom's Category	Continuous Assessment Tools			End Semester Examination
	Test1	Test 2	Other tools	
Remember	✓	✓	✓	✓
Understand	✓	✓	✓	✓
Apply	✓	✓	✓	✓
Analyse				
Evaluate				
Create				

<b>Mark Distribution of CIA</b>					
<b>Course Structure [L-T-P-J]</b>	<b>Attendance</b>	<b>Theory [L- T]</b>			<b>Total Marks</b>
		<b>Assignment</b>	<b>Test-1</b>	<b>Test-2</b>	
<b>3-1-0-0</b>	5	15	10	10	<b>40</b>
<b>Total Mark distribution</b>					
<b>Total Marks</b>	<b>CIA (Marks)</b>	<b>ESE (Marks)</b>		<b>ESE Duration</b>	
100	40	60		3 hours	
<b>End Semester Examination [ESE]: Pattern</b>					
<b>PATTERN</b>	<b>PART A</b>	<b>PART B</b>			<b>ESE Marks</b>
PATTERN 1	10 Questions, each question carries 2 marks	2 questions will be given from each module, out of which 1 question should be answered. Each question can have a maximum of 2 sub divisions.			60
	Marks: (2x10 =20 marks)	Each question carries 8 marks.  Marks: (5x8 = 40 marks) Time: 3 hours			
	Total Marks: 20	Total Marks: [5x8 = 40 marks]			
<b>SYLLABUS</b>					
<b>MODULE I : (Multivariable Calculus and Applications)</b>					
Partial derivatives, Partial derivatives of functions of two variables, The partial derivative functions, Partial derivatives viewed as rates of change and slopes, Implicit partial differentiation, Partial derivatives of functions with more than two variables, Higher-order partial derivatives, Equality of mixed partials, Differentiability, Differentials, Local linear approximations, The chain rule, Chain rules for partial derivatives, Other versions of the chain rule, Implicit differentiation, Maxima and minima of functions of two variables - Extrema, Finding relative extrema, The second partials test.					
<b>MODULE II : (Multiple integrals and applications)</b>					
Double integrals (Cartesian), Double integrals over nonrectangular regions, Reversing the order of integration, Change of coordinates (Cartesian to polar), Finding area and volume using double integrals, Application of multiple integrals-mass and center of gravity of inhomogeneous laminas using double integral. Triple integrals, volume calculated as triple integral (exclude problems of intersection of solids), and triple integral in cylindrical coordinates.					
<b>MODULE III : (Vector Differentiation)</b>					
Vector valued functions of single variable, derivative of vector function and geometrical interpretation, motion along a curve –velocity, speed and acceleration.					

Concept of scalar and vector fields, Gradient and its properties, directional derivative, divergence and curl, Line integrals of vector fields, work as line integral, Conservative vector fields, independence of path and potential function (results without proof).

**MODULE IV : (Vector Integration)**

Green's Theorem (for simply connected domains, without proof) and applications to evaluating line integrals and finding areas. Divergence theorem (without proof) and its applications to flux integrals, Stokes' theorem (without proof) and its applications to finding line integrals of vector fields and work done. Evaluation of Surface integral using Stokes' theorem.

**MODULE V : (Linear Algebra)**

Systems of linear equations, Solution by Gauss elimination, row echelon form and rank of a matrix, fundamental theorem for linear systems (homogeneous and non-homogeneous, without proof), eigenvalues and eigenvectors, Properties of eigenvalues and eigenvectors, Diagonalization of matrices.

**Text books**

1. H. Anton, I. Biven, S. Davis, "Calculus", Wiley, 10th edition, 2015.
2. Erwin Kreyszig, Advanced Engineering Mathematics, 10<sup>th</sup> Edition, John Wiley & Sons, 2016.

**Reference books**

1. J. Stewart, Essential Calculus, Cengage, 2nd edition, 2017
2. G.B. Thomas and R.L. Finney, Calculus and Analytic geometry, 9<sup>th</sup> Edition, Pearson, Reprint, 2002.
3. Peter V. O'Neil, Advanced Engineering Mathematics, Cengage, 7th Edition, 2012
4. Veerarajan T., Engineering Mathematics for first year, Tata McGraw-Hill, New Delhi, 2008.
5. B.S. Grewal, Higher Engineering Mathematics, Khanna Publishers, 36 Edition, 2010.
6. Dr. Joydeep Dutta, Calculus of Several Real Variables, IIT Kanpur, [NPTEL], <https://nptel.ac.in/courses/111104125> (Relevant sections)
7. Prof. Gilbert Strang, Linear Algebra [MITOPENCOURSEWARE]
8. <https://ocw.mit.edu/courses/18-06-linear-algebra-spring-2010/> (Relevant sections)

**COURSE CONTENTS AND LECTURE SCHEDULE**

No.		No. of Hours[45 hours]
<b>MODULE 1</b> [9 hours]		
1.1	Partial derivatives, Partial derivatives of functions of two variables	1
1.2	Implicit partial differentiation, Partial derivatives of functions with more than two variables	1
1.3	Higher-order partial derivatives, Equality of mixed partials	1
1.4	Differentials	1
1.5	Local Linear approximations	1
1.6	Chain rule, Implicit differentiation	1
1.7	Total derivative	1

1.8	Maxima and minima of functions of two variables - Extrema, Finding relative extrema, The second partials test.	1
1.9	Maxima and minima of functions of two variables(continued)	1
<b>MODULE II</b> [10 hours]		
2.1	Double integrals (Cartesian)-evaluation	1
2.2	Double integrals(continued)	1
2.3	Change of order of integration in double integrals	1
2.4	Change of coordinates (Cartesian to polar)	1
2.5	Finding areas and volumes	1
2.6	Finding areas and volumes(continued)	1
2.7	Mass and center of gravity of plane laminas	1
2.8	Triple integrals,	1
2.9	Volume calculated as triple integral (exclude problems of the intersection of solids)	1
2.10	Triple integral in cylindrical coordinates	1
<b>MODULE III</b> [9 hours]		
3.1	Vector valued function of a scalar variable	1
3.2	Derivative of vector valued function of scalar variable - geometrical meaning	1
3.3	Motion along a curve-speed , velocity, acceleration	1
3.4	Gradient and its properties	1
3.5	Directional derivative	1
3.6	Divergent and curl	1
3.7	Line integrals with respect to arc length, line integrals of vector fields.	1
3.8	Work done as line integral	1
3.9	Conservative vector field, independence of path, potential function	1
<b>MODULE IV</b> [9 hours]		
4.1	Green's theorem and its applications	1
4.2	Green's theorem and its applications(continued)	1
4.3	Green's theorem and its applications(continued)	1
4.4	Divergence theorem and applications	1
4.5	Divergence theorem and applications(continued)	1
4.6	Divergence theorem and applications(continued)	1
4.7	Stokes theorem and applications	1
4.8	Stokes theorem and applications(continued)	1
4.9	Stokes theorem and applications(continued)	1
<b>MODULE V</b> [8 hours]		
5.1	Systems of linear equations, Solution by Gauss elimination	1
5.2	Row echelon form	1

5.3	Finding rank from row echelon form	1
5.4	Fundamental theorem for linear systems (homogeneous and non-homogeneous, without proof)	1
5.5	Eigenvalues and eigenvectors	1
5.6	Properties of eigenvalues and eigenvectors	1
5.7	Diagonalization of matrices	1
5.8	Diagonalization of matrices(continued)	1

### CO Assessment Questions

1	<p>1. A manufacturer makes two models of an item, standard and deluxe. It costs Rs. 40 to manufacture the standard model and Rs. 60 for the deluxe. A market research firm estimates that if the standard model is priced at rupees <math>x</math> and the deluxe at rupees <math>y</math>, then the manufacturer will sell <math>500(y - x)</math> of the standard items and <math>45,000 + 500(x - 2y)</math> of the deluxe each year. How should the items be priced to maximize the profit?</p> <p>2. Determine the dimension of the rectangular box open at the top, having a volume 32 cubic ft and requiring the least amount of material for its construction.</p> <p>3. The temperature <math>T(x, y, z)</math> at any point <math>(x, y, z)</math> in space is given by <math>T(x, y, z) = x^2 + y^2 + z^2</math>. Find the differential <math>dT</math> at a point <math>(a, b, c)</math>, and use it to approximate the change in temperature when the coordinates change by small amounts <math>\delta x, \delta y</math>, and <math>\delta z</math>.</p> <p>4. Use a CAS(MATLAB/SCILAB/Python) to generate a contour plot of <math>f(x, y) = 2y^2x - yx^2 + 4xy</math> for <math>-5 \leq x \leq 5</math> and <math>-5 \leq y \leq 5</math>, and use the plot to approximate the locations of all relative extrema and saddle points in the region. Check your answer using calculus, and identify the relative extrema as relative maxima or minima.</p> <p>5. <b>Team Work</b> : Use the method of least squares(refer exercise 13.8 in text 1) to find the values of <math>m</math> and <math>b</math> in the regression line <math>y=mx+b</math> that best fits the data <math>(x_1, y_1), (x_2, y_2), \dots, (x_n, y_n)</math>. The team has to make a presentation elaborating the solution and illustrating the method on any data set (using any programming language).</p>
2	<p>1. Consider a thin metal plate that occupies the triangular region <math>R</math> in the <math>xy</math>-plane with vertices at <math>(0, 0)</math>, <math>(2, 0)</math>, and <math>(0, 3)</math>. The temperature on the plate is given by <math>T(x, y) = x^2 + y^2</math>, where <math>x</math> and <math>y</math> are the coordinates of a point. Find the average temperature over the region <math>R</math>.</p> <p>2. A water tank has the shape of a hemisphere with a radius of 4 meters. The tank is filled with water up to a height of <math>h</math> meters. Find the total weight of the water in the tank using a double integral, assuming the density of water is constant.</p> <p>3. Find the mass and centre of gravity of a triangular lamina with vertices</p>



	<p>(0,0), (2,1), (0,3) if the density function is <math>f(x, y) = x + y</math>.</p> <p>4. Use a CAS(MATLAB/SCILAB/Python) to approximate the intersections of the curves <math>y = \sin x</math> and <math>y = x/2</math>, and then approximate the volume of the solid in the first octant that is below the surface <math>z = \sqrt{1 + x + y}</math> and above the region in the <math>xy</math>-plane that is enclosed by the curves.</p> <p>5. <b>Team Work</b> : The following initial steps can be used to express a triple integral over a solid <math>G</math> as an iterated triple integral: First project <math>G</math> onto one of the coordinate planes to obtain a region <math>R</math>, and then project <math>R</math> onto one of the coordinate axes. Describe how you would use these steps to find the limits of integration. Illustrate your discussion with an example using any software. The team has to make a presentation elaborating the procedure.</p>
3	<p>1. A heat-seeking particle is located at the point (2, 3) on a flat metal plate whose temperature at a point <math>(x, y)</math> is <math>T(x, y) = 10 - 8x^2 - 2y^2</math>. Find an equation for the trajectory of the particle if it moves continuously in the direction of maximum temperature increase.</p> <p>2. A vector field <math>F(x, y, z) = (y, x, 2z)</math> represents the velocity of a fluid flow in three-dimensional space. Determine the divergence and curl of <math>F</math>, and interpret the physical meaning of these vector operations.</p> <p>3. A vector field <math>F(x, y, z) = (x^2, xy, yz)</math> represents a force field in three-dimensional space. Show that <math>F</math> is conservative and find a potential function for <math>F</math>. Also, evaluate the work done by <math>F</math> along a curve <math>C</math> from point <math>A(1, 2, 0)</math> to point <math>B(3, 1, 4)</math>.</p> <p>4. Visualize any five vector fields relevant to your domain using CAS(MATLAB/SCILAB/Python).</p> <p>5. <b>Team Work</b> : Suppose that <math>C</math> is a circle in the domain of a conservative nonzero vector field in the <math>xy</math>-plane whose component functions are continuous. Explain why there must be at least two points on <math>C</math> at which the vector field is normal to the circle. Also, illustrate using figures drawn in any software. Does the result remain true if the circle <math>C</math> is replaced by a square? Explain. The team has to make a presentation elaborating the solution.</p>
4	<p>1. Suppose we have a region <math>R</math> in the <math>xy</math>-plane bounded by a simple closed curve <math>C</math>. The temperature distribution in this region is given by the function <math>T(x, y) = 2x^2 - 3y^2</math>. Calculate the total heat flux across the boundary curve <math>C</math> using Green's theorem.</p> <p>2. Find the outward flux of the vector field <math>F(x, y, z) = z\hat{k}</math> across the sphere <math>x^2 + y^2 + z^2 = a^2</math> using divergence theorem.</p> <p>3. Calculate the work done by force field <math>F(x, y, z) = 2xi + 3yj + 4zk</math> where <math>C</math> is the curve defined by the ellipse <math>\frac{x^2}{9} + \frac{y^2}{4} = 1</math> in the counterclockwise direction using Stokes' Theorem.</p>

4. Use a CAS(MATLAB/SCILAB/Python) to verify Green's Theorem for the function  $F = e^y \mathbf{i} + ye^x \mathbf{j}$  where
- C is the circle  $x^2 + y^2 = 1$
  - C is the boundary of the region enclosed by  $y = x^2$  and  $x = y^2$ .
5. **Team Work** : Explain with graphics how a rolling planimeter is used to calculate the area of a region. Describe the relationship between these devices and Green's Theorem. Illustrate an example. The team has to make a presentation elaborating the solution.

1. Using Kirchhoff's laws and showing the details, find the currents:

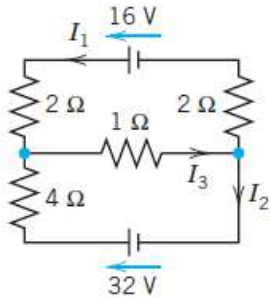

2. Find the growth rate in the Leslie model (see Example 3. Sec8.2 Text2)

with the matrix as given 
$$\begin{bmatrix} 0 & 3.45 & 0.60 \\ 0.9 & 0 & 0 \\ 0 & 0.45 & 0 \end{bmatrix}.$$

5

3. A system is represented by the state equation 
$$\begin{bmatrix} \frac{dx_1}{dt} \\ \frac{dx_2}{dt} \end{bmatrix} = \begin{bmatrix} 0 & 1 \\ -4 & -5 \end{bmatrix} \begin{bmatrix} x_1 \\ x_2 \end{bmatrix} +$$

$\begin{bmatrix} 0 \\ 1 \end{bmatrix} u$ . Show that it is controllable.

4. In circuit theory a set of linear equations with electrical components such as resistance inductance capacitors current voltage etc. Identify a problem solved using matrix algebra and solve it using CAS(MATLAB/SCILAB/Python).
5. **Team Work** : Identify five application-oriented problems from your domain and its solution. Give a PPT illustrating the relevance of the problem.

24PYP102	ENGINEERING PHYSICS (FOR CIRCUIT BRANCHES)						L	T	P	J	S	C	Year of Introduction
							2	1	2	0	4	4	2024
<p><b>Preamble:</b> Enable the students to enhance the fundamental knowledge in physics and its applications relevant to various streams of Engineering and Technology. The topics like Oscillations and Wave Motion, Wave Optics, Quantum Mechanics for Engineers, Introduction to Electromagnetic Theory and Introduction to Solids are covered in the syllabus. This helps the learners to explore the advanced concepts in physics and to do interdisciplinary research.</p>													
<p><b>Prerequisite:</b> Higher secondary level Physics and Mathematics.</p>													
<p><b>Course Outcomes:</b> After the completion of the course the student will be able to</p>													
<b>CO1</b>	Interpret the characteristics of mechanical and electrical oscillators. [Apply level]												
<b>CO2</b>	Demonstrate the concepts of interference and diffraction for the determination of wavelength of unknown sources. [Apply level]												
<b>CO3</b>	Use the basic principles of quantum mechanics to determine the energy eigen values and eigen functions of particle in a box. [Apply level]												
<b>CO4</b>	Apply the Maxwell's equations in estimating the speed of light. [Apply level]												
<b>CO5</b>	Use low power lasers in doing optical and fibre optical experiments. [Apply level]												
<b>CO - PO MAPPING</b>													
CO	PO1	PO2	PO3	PO4	PO5	PO6	PO7	PO8	PO9	PO10	PO11	PO12	
<b>CO1</b>	3	3			3			3	3	3		3	
<b>CO2</b>	3	3			3			3	3	3		3	
<b>CO3</b>	3	3			3							3	
<b>CO4</b>	3												
<b>CO5</b>	3							3	3	3			
<b>Assessment Pattern for Theory component</b>													
Bloom's Category	Continuous Assessment Tools			End Semester Examination									
	Test 1	Test 2	Other tools										
Remember	✓	✓	✓	✓									
Understand	✓	✓	✓	✓									
Apply	✓	✓	✓	✓									
Analyse													

Evaluate				
Create				
<b>Assessment Pattern for Lab component</b>				

Bloom's Category	Continuous Assessment Tools	
	Class work	Test1
Remember		
Understand	✓	✓
Apply	✓	✓
Analyse		
Evaluate		
Create		

Mark Distribution of CIA							
Course Structure [L-T-P-J]	Attendance	Theory [L- T]			Practical [P]		Total Marks
		Assignment	Test-1	Test-2	Class work	Lab Exam	
<b>2-1-2-0</b>	5	10	12.5	12.5	10	10	<b>60</b>
Total Marks distribution							
Total Marks	CIA (Marks)		ESE (Marks)		ESE Duration		
100	60		40		2.5 hours		

**End Semester Examination [ESE]: Pattern**

PATTERN	PART A	PART B	ESE Marks
PATTERN 2		<p>2 questions will be given from each module, out of which 1 question should be answered. Each question can have a maximum of 2 sub divisions.</p> <p>Each question carries 8 marks.</p> <p>Marks: (5x 8 = 40 marks)</p> <p>Time: 2.5 hours</p>	40
	Total Marks: 0	Total Marks:[5x8= 0marks]	

## SYLLABUS

### **MODULE I : Oscillations and Wave Motion (7 hours)**

#### **Simple harmonic motion, damped and forced simple harmonic oscillator**

Damped harmonic oscillator: derivation of equation of motion and its solution, under damped oscillators; energy decay in damped harmonic oscillator, Quality factor (qualitative)- Forced harmonic oscillator: equation of motion and its solution (No derivation), Amplitude resonance - Electrical analogy of mechanical oscillators

- Numerical problems.

#### **Transverse waves in one dimension**

Transverse and Longitudinal waves - Transverse waves on a stretched string; the wave equation on a string, derivation for the velocity and frequency of transverse vibrations on a stretched string- Numerical problems.

### **MODULE II : Wave Optics (7 hours)**

#### **Interference of light by amplitude splitting**

Interference of reflected light in thin films; Interference in thin films (Cosinelaw); Derivation of the conditions of constructive and destructive Interference

- Air Wedge; Determination of thickness of a thin wire - Antireflection coatings

- Numerical problems.

#### **Diffraction of light**

Fresnel and Fraunhofer classes of diffraction - Diffraction grating -Grating equation - Rayleigh's criterion for limit of resolution - Resolving power of a grating with expression (no derivation), Comparison of interference and diffraction - Numerical problems.

### **MODULE III : Quantum Mechanics for Engineers (8 hours)**

#### **Wave nature of particles and the Schrodinger equation**

Wave-Particle dualism; de Broglie hypothesis, de-Broglie wavelength - Wave function; Admissibility conditions, Physical significance, Probability density, Normalization condition - Time dependent Schrödinger wave equation - Time independent Schrödinger wave equation.

#### **Applying the Schrodinger equation**

Particle in a one-dimensional box; Energy Eigen values and normalized wave function, concept of quantum number, Quantum mechanical tunnelling (qualitative) - Numerical problems.

### **MODULE IV : Introduction to Electromagnetic Theory (7 hours)**

Physics of gradient, divergence and curl - Gauss's divergence theorem and Stoke's theorem- Equation of continuity, Deduction of Maxwell's equations in vacuum - Electromagnetic waves: Electromagnetic wave equation in free space, velocity of Electromagnetic waves in free space, Poynting's theorem (Qualitative) - Numerical problems.

**MODULE V: Introduction to Solids (7 hours)**

Pauli's exclusion principle - Particle in a three-dimensional box; expression for Energy Eigen value and normalized wave function - Concept of quantum state and degeneracy - The density of states; Expression for density of states for a spinless particle, density of states for an electron. Effective mass concept (qualitative). Numerical problems.

**Text books**

1. M.N.Avadhanulu, P.G.Kshirsagar, TVS Arun Murthy "A Text book of Engineering Physics", S.Chand &Co., Revised Edition 2019.
2. H.K.Malik , A.K. Singh, "Engineering Physics" McGraw Hill Education, Second Edition 2017.

**Reference books**

1. Arthur Beiser, "Concepts of Modern Physics ", Tata McGraw Hill Publications, 6th Edition 2003.
2. D. .K. Bhattacharya, Poonam Tandon, "Engineering Physics", Oxford University Press, 2015.
3. Md.N.Khan & S.Panigrahi "Principles of Engineering Physics 1&2", Cambridge University Press, 2016.
4. Aruldhas G., "Engineering Physics", PHI Pvt. Ltd., 2015.
5. Ajoy Ghatak, "Optics", Mc Graw Hill Education, Sixth Edition, 2017.
6. Premlet B., "Advanced Engineering Physics", Phasor Books, 11th edition, 2021.
7. I. Dominic and. A. Nahari, "A Text Book of Engineering physics", Owl Books Publishers, Revised edition, 2016.
8. H.D Young and R.A Freedman, University Physics with Modern Physics 2020, 15th Edition, Pearson, USA.
9. Introduction to solid state devices, B Premlet, Phasor Books.
10. Griffiths "Introduction to Electrodynamics" 4th Edition, Pearson.

**COURSE CONTENTS AND LECTURE SCHEDULE**

No.		No. of Hours[36]
<b>MODULE 1: Oscillations and Wave Motion (7 hours)</b>		
1.1	Simple harmonic motion, damped and forced simple harmonic oscillator. Damped harmonic oscillator: derivation of equation of motion and its solution, under damped oscillators; energy decay in damped harmonic oscillator.	1
1.2	Quality factor (qualitative), Numerical problems.	1
1.3	Forced harmonic oscillator: equation of motion and its solution (No derivation).	1
1.4	Amplitude resonance, Numerical problems	1
1.5	Electrical analogy of mechanical oscillators- Numerical problems.	1

1.6	Transverse waves in one dimension Transverse and Longitudinal waves - Transverse waves on a stretched string; the wave equation on a string, derivation for the velocity and frequency of transverse vibrations on a stretched string.	1
1.7	Numerical problems.	1
<b>MODULE II: Wave Optics (7 hours)</b>		
2.1	Interference of light by amplitude splitting Interference of reflected light in thin films; Interference in thinfilms (Cosine law).	1
2.2	Derivation of the conditions of constructive and destructive Interference, Numerical problems	1
2.3	Air Wedge; Determination of thickness of a thin wire	1
2.4	Antireflection coatings - Numerical problems.	1
2.5	Diffraction of light Fresnel and Fraunhofer classes of diffraction - Diffraction grating - Grating equation.	1
2.6	Rayleigh's criterion for limit of resolution - Resolving power of a grating with expression (no derivation), Numerical problems.	1
2.7	Comparison of interference and diffraction, Numerical problems.	1
<b>MODULE III: Quantum Mechanics for Engineers (8 hours)</b>		
3.1	Wave nature of particles and the Schrodinger equation Wave-Particle dualism; de Broglie hypothesis, de-Broglie wavelength, Numerical problems.	1
3.2	Wave function; Admissibility conditions, Physical significance, Probability density, Normalization condition.	1
3.3	Time dependent Schrödinger wave equation.	1
3.4	Time independent Schrödinger wave equation (no derivation).	1
3.5	Applying the Schrodinger equation Particle in a one-dimensional box; Energy Eigen values and normalized wave function, Numerical problems.	1
3.6	Concept of quantum numbers.	1
3.7	Quantum mechanical tunnelling (qualitative).	1
3.8	Numerical problems.	1
<b>MODULE IV: Introduction to Electromagnetic Theory (7 hours)</b>		
4.1	Physics of gradient, divergence and curl, Numerical problems.	1
4.2	Gauss's divergence theorem and Stoke's theorem- Equation of continuity.	1

4.3	Deduction of Maxwell's equations in vacuum (first two equations).	1
4.4	Deduction of Maxwell's equations in vacuum (third and fourth equations).	1
4.5	Electromagnetic waves: Electromagnetic wave equation in free space.	1
4.6	Velocity of Electromagnetic waves in free space, Numerical problems.	1
4.7	Poynting's theorem (Qualitative) - Numerical problems.	1
<b>MODULE V: Introduction to Solids (7 hours)</b>		
5.1	Pauli's exclusion principle.	1
5.2	Particle in a three-dimensional box.	1
5.3	Expression for Energy Eigen value and normalized wavefunction.	1
5.4	Concept of quantum state and degeneracy.	1
5.5	The density of states; Expression for density of states for a spinless particle.	1
5.6	Density of states for an electron.	1
5.7	Effective mass concept (qualitative). Numerical problems.	1

#### **LESSON PLAN FOR LAB COMPONENT**

<b>No.</b>	<b>Topic</b>	<b>No. of Hours</b>	<b>Experiment</b>
1	Oscillations	4	<ol style="list-style-type: none"> <li>1. Resonance phenomenon in mechanical oscillators.</li> <li>2. LCR Circuit – Forced and damped harmonic oscillations.</li> </ol>
2	Waves	4	<ol style="list-style-type: none"> <li>1. Melde's string apparatus- Measurement of frequency in the transverse mode.</li> <li>2. Melde's string apparatus- Measurement of frequency in the longitudinal mode.</li> </ol>
3	Interference	4	<ol style="list-style-type: none"> <li>1. Wave length measurement of a monochromatic source of light using Newton's Rings method.</li> <li>2. Determination of diameter of a thin wire or thickness of a thin strip of paper using air wedge method.</li> </ol>
4	Diffraction	4	<ol style="list-style-type: none"> <li>1. Determination of resolving power of a plane transmission grating.</li> <li>2. Determination of the wavelength of laser source using diffraction grating.</li> </ol>



5	Quantum Mechanics	4	<ol style="list-style-type: none"> <li>1. Determination of the particle size of lycopodium powder.</li> <li>2. Numerical demonstration of the discrete energy levels and wavefunctions using Schrodinger equation. (e.g., Particle in a box problem)</li> </ol>
6	Electromagnetic Theory	4	<ol style="list-style-type: none"> <li>1. Determine the characteristics of EM waves using Hertz experiment.</li> <li>2. Determination of Numerical aperture of optic fiber using Laser.</li> </ol>
(Any 6 experiments to be completed)			

### CO Assessment Questions

1	<ol style="list-style-type: none"> <li>1) Compute the frequency and Quality factor for an LCR circuit with <math>L = 2\text{mH}</math>, <math>C = 5\mu\text{F}</math> and <math>R = 0.2\Omega</math>.</li> <li>2) Frame any five numerical problems on oscillations with different difficulty levels and solve them.</li> <li>3) Identify the applications of the theory of oscillations in the field of engineering and prepare a Power Point presentation on any one system which failed in applying the theory of damped or forced oscillation. (Eg: Failed due to damping, resonance etc.)</li> <li>4) Determine experimentally the characteristics of an LCR oscillator.</li> </ol>
2	<ol style="list-style-type: none"> <li>1) Light of wavelength <math>6000\text{\AA}</math> falls normally on a wedge-shaped film. The two plates touch at one end and are separated at 10 cm from that end by a wire. If the bandwidth of interference pattern is 0.05mm, find the diameter of the wire.</li> <li>2) Design any three numerical problems on Interference and implement these using any one programming language and submit the source code and output.</li> <li>3) Write a brief report on the limitations of any one optical instrument used in engineering systems. Determine experimentally the wavelength of a laser source using diffraction grating.</li> </ol>
3	<ol style="list-style-type: none"> <li>1) Apply the appropriate Schrodinger equation and compute the first three energy eigen values and wave functions of a particle trapped inside a well.</li> <li>2) Make a video demonstrating any one Engineering System in which classical physics failed to give a perfect design and was designed with the aid of Quantum Mechanics.</li> </ol>

4	<ol style="list-style-type: none"><li>1) Determine the velocity of Electromagnetic waves in free space using Maxwell's equations.</li><li>2) Create a quiz based on numerical problems from electromagnetic theory using appropriate tool.</li></ol>
5	<ol style="list-style-type: none"><li>1) Determine experimentally the wavelength of a standard laser source using diffraction grating arrangement.</li><li>2) Determine experimentally the NA of an optic fibre cable.</li></ol>

<b>24EST104</b>	<b>FUNDAMENTALS OF ELECTRICAL ENGINEERING</b>	<b>L</b>	<b>T</b>	<b>P</b>	<b>J</b>	<b>S</b>	<b>C</b>	<b>Year of Introduction</b> <b>2024</b>
		<b>3</b>	<b>0</b>	<b>0</b>	<b>0</b>	<b>3</b>	<b>3</b>	
<b>Preamble:</b>								
To provide the students with fundamental knowledge in the field of Electrical Engineering. This course will enable the students to analyze electrical and magnetic circuits. The students will be able to choose appropriate electric machines for various applications.								
<b>Prerequisite:</b> Nil								
<b>Course Outcomes:</b> After the completion of the course the student will be able to								
<b>CO 1</b>	Solve DC electrical circuits using Circuit laws. (Apply level)							
<b>CO 2</b>	Solve simple magnetic circuits (Apply level)							
<b>CO 3</b>	Analyze simple A.C. electrical circuits (Analyse level)							
<b>CO 4</b>	Identify the benefits of three-phase systems for industrial electrical applications (Understand level)							
<b>CO 5</b>	Explain the principle of operation of electrical machines (Understand level)							

<b>CO - PO MAPPING</b>												
<b>CO</b>	<b>PO1</b>	<b>PO2</b>	<b>PO3</b>	<b>PO4</b>	<b>PO5</b>	<b>PO6</b>	<b>PO7</b>	<b>PO8</b>	<b>PO9</b>	<b>PO10</b>	<b>PO11</b>	<b>PO12</b>
<b>CO 1</b>	<b>3</b>	<b>1</b>										
<b>CO 2</b>	<b>3</b>	<b>2</b>										
<b>CO 3</b>	<b>3</b>				<b>2</b>			<b>2</b>	<b>1</b>			
<b>CO 4</b>	<b>3</b>											
<b>CO 5</b>	<b>3</b>											

<b>Assessment Pattern</b>				
<b>Bloom's Category</b>	<b>Continuous Assessment Tools</b>			<b>End Semester Examination</b>
	<b>Test1</b>	<b>Test 2</b>	<b>Other tools</b>	
Remember	✓	✓	✓	✓
Understand	✓	✓	✓	✓
Apply	✓	✓	✓	✓
Analyse			✓	
Evaluate				
Create				

<b>Mark Distribution of CIA</b>					
<b>Course Structure</b> <b>[L-T-P-J]</b>	<b>Attendance</b>	<b>Theory [L- T]</b>			<b>Total Marks</b>
		<b>Assignment</b>	<b>Test-1</b>	<b>Test-2</b>	
<b>3-0-0-0</b>	<b>5</b>	<b>15</b>	<b>10</b>	<b>10</b>	<b>40</b>

<b>Total Mark distribution</b>			
<b>Total Marks</b>	<b>CIA (Marks)</b>	<b>ESE (Marks)</b>	<b>ESE Duration</b>
100	40	60	3 hours
<b>End Semester Examination [ESE]: Pattern</b>			
PATTERN	PART A	PART B	ESE Marks
PATTERN 1	10 Questions, each question carries 2 marks  Marks: (2x10 =20 marks)	2 questions will be given from each module, out of which 1 question should be answered. Each question can have a maximum of 2 sub divisions.  Each question carries 8 marks. Marks: (5x8 = 40 marks) Time: 3 hours	<b>60</b>
	Total Marks: 20	Total Marks: [5x8 = 40 marks]	

<b>SYLLABUS</b>
<b>MODULE I: Introduction to electrical and magnetic circuits</b>
Introduction: Importance of Electrical Engineering in day-to-day life, types of Electrical elements - Ideal and practical Sources.
D. C. Circuits: Ohm's Law and Kirchhoff's Laws; Loop current; Steady state analysis with independent sources; Power and energy; Star- Delta conversion (Analysis of resistive networks only).
Magnetic circuits: MMF, field strength, flux density, reluctance, energy stored in magnetic circuits, Simple problems in series magnetic circuits.
Electromagnetism: Faradays Laws, Lenz's Law, Fleming's Rules, Statically and dynamically induced EMF; Concepts of self-inductance, mutual inductance and coefficient of coupling. Simple numerical problems.
<b>MODULE II: Single Phase AC Circuits</b>
Single Phase system: Generation of sinusoidal voltage. Series Circuits: Common signals and waveforms (Sine, Square, Triangle), RMS and Average value, form factor and peak factor of AC waveforms, Impedance of series circuits (RL, RC and RLC circuits). Phasor diagram of series circuits; Real, reactive and apparent power, power factor, Power triangle, Numerical Problems.
<b>MODULE III: Three Phase System</b>
Three Phase System: Generation of three phase voltages- advantages of three phase systems, star and delta connection, three wire and four wire systems, relation between line and phase voltages, line and phase currents. Expressions for power in three phase circuits; definition of phase sequence, balanced supply and balanced load; Relationship between line and phase values of balanced star and delta connections; Power in balanced three phase circuits. Numerical Problems.

**MODULE IV: DC Machines and Transformers**

DC Machines: Working principle of DC generator - types and constructional features - EMF equation of generator - Numerical Problems.

DC motor: Working principle - Significance of Back EMF - torque equation – types - characteristics (series and Shunt motors only) and applications - necessity of a starter for DC motor - Numerical Problems.

Transformer: Principle of operation and construction of single-phase transformers (core and shell types) - emf equation, losses.

**MODULE V: AC Machines and Energy storage**

Three Phase Induction Motors: Concept of rotating magnetic field - principle of operation, types and constructional features - Slip and its significance - applications of squirrel cage and slip ring motors - Necessity of a starter - star-delta starter.

Energy storage devices: fundamentals of batteries - types - primary - Secondary batteries, Lead-Acid Batteries, Lithium-Ion Batteries – characteristics-advantages - disadvantages

**Text books**

1. Hughes, Electrical Technology, Pearson, 10th Edition, 2011.
2. Fitzgerald and Higginbotham, Basic Electrical Engineering, McGraw Hill Inc, 1981.
3. D.P. Kothari and I.J. Nagrath, Basic Electrical Engineering, 3rd Edition, TMH, 2009
4. Basic Electrical Engineering, D. C. Kulshreshtha, McGraw-Hill Education, Revised first edition, 2019.

**Reference books**

1. W. H. Hayt, Jr J. E. Kemmerly and S. M. Durbin, Engineering Circuit Analysis, 7th Edn TMH, 2010.
2. Electrical Engineering Fundamental, Vincent Del Toro, Prentice Hall, New Delhi.
3. Fundamentals of Electrical Engineering and Electronics, B.L. Theraja, S Chand and Company, Reprint Edition 2013.
4. Principles Electrical Engineering and Electronics, V.K Mehata, Rohit Mehta, S Chand and Company, 2nd edition, 2015.
5. M.S. Sukhija and T.K. Nagsarkar, Basic Electrical and Electronics Engineering, Oxford University Press, 2012.
6. S. B. Lal Seksena and Kaustuv Dasgupta, “Fundamentals of Electrical Engineering”, Cambridge University Press.
7. NPTEL course on Basic Electrical Technology, Prof. G. D. Roy, IIT Kharagpur.

<b>COURSE CONTENTS AND LECTURE SCHEDULE</b>		
No.		No. of Hours (36 Hours)
<b>MODULE 1</b>		
1.1	Importance of Electrical Engineering in day-to-day life, types of Electrical elements, Ideal and practical Sources	1
1.2	Ohm's Law and Kirchhoff's Laws; Loop current method	1
1.3	Steady state analysis with independent sources; Power and energy; Star-Delta conversion (Analysis of resistive networks only)	1
1.4	Numerical problems on topic 1.3	1
1.5	MMF, field strength, flux density, reluctance, energy stored in magnetic circuits, Simple problems in series magnetic circuits	1
1.6	Faradays Laws, Lenz's; Law, Fleming's Rules, Statically & dynamically induced EMF	
1.7	Concepts of self-inductance, mutual inductance and coefficient of coupling	1
1.8	Simple Numerical Problems	1
<b>MODULE II</b>		
2.1	Single Phase system: Generation of sinusoidal voltage	1
2.2	Series Circuits: Common signals and waveforms (Sine, Square, Triangle), RMS and Average value, form factor and peak factor of AC waveforms	1
2.3	Numerical Problems on topic 2.2	1
2.4	Impedance of series circuits (RL, RC and RLC circuits). Phasor diagram of series circuits	1
2.5	Real, reactive and apparent power, power factor and Power triangle	1
2.6	Numerical Problems on topic 2.4	1
2.7	Numerical Problems on topic 2.5	1
<b>MODULE III</b>		
3.1	Three Phase System: Generation of three phase voltages- advantages of three phase systems, star and delta connection, three wire and four wire systems	1
3.2	Relation between line and phase voltages, line and phase currents	1
3.3	Expressions for power in three phase circuits	1
3.4	Definition of phase sequence, balanced supply and balanced load;	1
3.5	Relationship between line and phase values of balanced star and delta connections	1
3.6	Power in balanced three phase circuits- Numerical Problems	1

<b>MODULE IV</b>		
4.1	Working features; principle of DC generator; Types and constructional features	1
4.2	EMF equation of generator, Numerical Problems	1
4.3	Working principle of DC motor; Significance of Back EMF, torque equation	1
4.4	Numerical problems.	1
4.5	Types of D.C. motors, characteristics (series and Shunt motors only)	1
4.6	Application of DC Motors	1
4.7	Necessity of a starter for DC motor	1
4.8	Principle of operation and construction of single-phase transformers (core and shell types)	1
4.9	Emf equation, losses – Simple numerical problems	1
<b>MODULE V</b>		
5.1	Three Phase Induction Motors: Concept of rotating magnetic field - Principle of operation	1
5.2	Types and constructional features; Slip and its significance	1
5.3	Applications of squirrel cage and slip ring motors	1
5.4	Necessity of a starter, star-delta starter	1
5.5	Energy storages: fundamentals of batteries - types - primary - Secondary batteries, Lead-Acid Batteries- - characteristics - advantages - disadvantages	1
5.6	Lithium-Ion Batteries - characteristics - advantages - disadvantages	1

<b>CO Assessment Questions</b>	
CO 1	<p>Find the equivalent resistance between A and B for the network shown below</p> <div style="text-align: center;"> </div> <p style="text-align: right;">(Apply)</p>

CO 1	Compare the power consumed in star and delta circuits using the same resistances as branches.
CO 2	An Iron ring of cross-sectional area $1.1 \text{ cm}^2$ is wound with a coil of 3000 turns. Calculate the magnetizing current required to produce a flux of 0.2 mWb in the iron path if mean length of the path is 32 cm and relative permeability of iron is 2500. Neglect magnetic leakage and fringing.
CO 2	How is transformer behaving as a magnetic isolator?
CO 3	A sinusoidal voltage $V = 240 \angle 15^\circ$ of frequency 50Hz is applied to a series RL circuit consisting of $R = 10\Omega$ and $L = 0.25 \text{ H}$ . Calculate (i) rms current and its phase angle (ii) power factor (iii) average power (iv) reactive power and (v) apparent power drawn by the circuit.
CO 3	Submit a report on, case study of an AC circuit application
CO 3	Circuit De-bugging competition
CO 4	Derive the emf equation of a transformer
CO 5	Justify the necessity of starters in three phase induction motor



24EST105	FUNDAMENTALS OF ELECTRONICS ENGINEERING	L	T	P	J	S	C	Year of Introduction 2024
		3	0	0	0	3	3	

**Preamble:** The aim of this course is to provide a fundamental idea about electronic devices, circuits and communication systems. The course covers the basics of electronic circuits, integrated circuits, instrumentation system and communication systems.

**Prerequisite:** Nil

**Course Outcomes:** After the completion of the course the student will be able to

- CO 1** Explain the physics, structure and working of different electronic devices.
- CO 2** Illustrate the working of basic circuits using diodes and BJTs.
- CO 3** Implement Boolean functions using logic gates
- CO 4** Explain basic op-amp circuits
- CO 5** Describe the principle of operation of transducers and basic measuring instruments.
- CO 6** Discuss about the fundamental principles of various communication systems.

**CO - PO MAPPING**

CO	PO1	PO2	PO3	PO4	PO5	PO6	PO7	PO8	PO9	PO10	PO11	PO12
CO 1	✓							✓	✓	✓		
CO 2	✓	✓			✓							✓
CO 3	✓				✓							✓
CO 4	✓											
CO 5	✓											
CO 6	✓							✓	✓	✓		

**Assessment Pattern**

Bloom's Category	Continuous Assessment Tools			End Semester Examination
	Test1	Test 2	Other tools	
Remember	✓	✓	✓	✓
Understand	✓	✓	✓	✓
Apply			✓	
Analyse				
Evaluate				
Create				

Mark Distribution of CIA					
Course Structure [L-T-P-J]	Attendance	Theory [L- T]			Total Marks
		Assignment	Test-1	Test-2	
3-0-0-0	5	15	10	10	40
<b>Total Mark distribution</b>					
<b>Total Marks</b>		<b>CIA (Marks)</b>	<b>ESE (Marks)</b>		<b>ESE Duration</b>
100		40	60		3 Hours
<b><u>End Semester Examination [ESE]: Pattern</u></b>					
PATTERN	PART A	PART B			ESE Marks
PATTERN 1	10 Questions, each question carries 2 marks	2 questions will be given from each module, out of which 1 question should be answered. Each question can have a maximum of 2 sub divisions.			60
	Marks: (2x10 =20 marks)	Each question carries 8 marks. Marks: (5x8 = 40 marks) Time: 3 hours			
	Total Marks: 20	Total Marks: [5x8 = 40 marks]			
<b>SYLLABUS</b>					
<b>MODULE I: Electronic Components &amp; Devices (8 hours)</b>					
Classification of materials based on conductivity: Conductors, Semiconductors and Insulators. Intrinsic and extrinsic semiconductors. Active Components: PN junction diodes- structure, working, Current equation, VI characteristics, Zener diode: Avalanche breakdown and Zener breakdown and characteristics. Bipolar Junction Transistor: structure, working. Comparison of the three transistor configurations and their applications. N channel enhancement mode MOSFET: Structure and working. Comparison of BJT and MOSFET					
<b>MODULE II: Electronic Circuits (6 hours)</b>					
Block diagram and basic elements of DC power supply. Diode Circuits: Half wave and Full wave Rectifiers – working and comparison of parameters. Capacitor Filter. Zener voltage regulator. BJT Circuits: Transistor as a switch, Transistor as an amplifier. Relay vs Transistor switch					
<b>MODULE III: Integrated Circuits (6 hours)</b>					
Concept of integrated circuit, scales of integration, Types of ICs – Digital & Analog ICs Operational Amplifier: Ideal characteristics, inverting and non-inverting					

amplifiers, comparator. Digital Circuits: Boolean algebra, De- Morgan's theorem, Basic logic gates and universal gates, Minimization of logic expressions using Boolean algebra and realization using gates

#### **MODULE IV: Electronic Instrumentation (6 hours)**

Block diagram of electronic instrumentation system

Sensors and Transducers: Sensors and Transducers: Active and Passive transducers- photoelectric transducer (Photodiode, Solar Cell), Piezoelectric transducer, accelerometer, Force sensor (Strain gauge), Displacement sensor (LVDT), Temperature sensor (Thermistor), light sensor (LDR) and their applications.

#### **MODULE V: Communication Systems (8 hours)**

Introduction, need for modulation, frequency bands used for various communication systems. Radio communication: principle of AM, FM, comparison of AM & FM. Radio Receiver: Block diagram of AM super heterodyne receiver

Mobile Communication: Basic principles of cellular communications, principle and block diagram of GSM, concept of frequency reuse, hand off – soft and hard hand off.

Pulse Code Modulation, Various Digital Modulation Techniques-ASK, PSK, FSK

Basics of Networking, Network Topologies-Bus, Ring, Star and hybrid topology, Classifications of Computer Networks- LAN, MAN, WAN

#### **Text books**

1. Robert L. Boylestad and Louis Nashelsky, Electronic Devices and Circuit Theory, Pearson, 11th Ed., 2015.
2. John M Yarbrough, Digital Logic Applications & Design, Cengage Learning India, 1<sup>st</sup> edition, 2009.
3. David A. Bell, Electronic Instrumentation and Measurements, Oxford, 3<sup>rd</sup> edition.
4. Wayne Tomasi, Electronic Communications System : Fundamentals Through Advanced - Pearson education, 5<sup>th</sup> edition, 2008.

#### **Reference books**

1. David A Bell, Electronic Devices & Circuits, Oxford, 5<sup>th</sup> edition, 2017.
2. Chinmoy Saha, Arindam Halder, Debarati Ganguly, Basic Electronics Principles & Applications, Cambridge University Press, 2018
3. Millman, Halkias & Parikh, Integrated Electronics, Mc Graw Hill, 2nd Edition, 2012.
4. S. Sedra and K. C. Smith, Microelectronic Circuits, Oxford University Press, 6th edition
5. Anil K Maini, Varsha Agarwal, Electronic Devices & Circuits, John Wiley & Sons, 2020.
6. Bhargava, Basic Electronics and Linear circuits, Mc Graw Hill Education, 2<sup>nd</sup> edition, 2017.
7. Data Communication and Networking, Behrouz A Forouzan, McGraw-Hill Education

<b>COURSE CONTENTS AND LECTURE SCHEDULE</b>		
No.		No. of Hours
<b>MODULE 1</b>		
1.1	Introduction, Classification of materials based on conductivity: Conductors, Semiconductors and Insulators, conductivity range.	1
1.2	Intrinsic and extrinsic semiconductors – doping, concept of majority and minority carriers.	1
1.3	Active Components: PN junction diode - Structure, Unbiased diode - Depletion layer and Barrier potential, Principle of operation with forward biasing and reverse biasing, VI Characteristics	1
1.4	Active Components: Zener diode - Avalanche breakdown and Zener breakdown and Zener characteristics.	1
1.5	Active Components: Bipolar Junction Transistor: n-p-n transistor - structure, working.	1
1.6	Transistor configuration: CE transistor characteristics only, three regions of operations and applications.	1
1.7	Active Components: N channel enhancement mode MOSFET: Structure, working. Comparison of BJT & MOSFET.	2
<b>MODULE II ( Analysis &amp; Derivation not required)</b>		
2.1	Block diagram and basic elements of DC power supply. Diode Circuits: Half wave rectifier – working, ripple factor, rectification efficiency, peak inverse voltage.	1
2.2	Full wave bridge rectifier – working, ripple factor, rectification efficiency, peak inverse voltage. Comparison of half wave rectifier & full wave rectifier	1
2.3	Capacitor Filter, Zener voltage regulator – working, line and load regulation.	1
2.4	BJT circuits: Transistor as a switch, Transistor as an amplifier	2
2.5	Performance comparison of relay and transistor switch	1
<b>MODULE III</b>		
3.1	Analog and Digital ICs: Concept of integrated circuit, scales of integration, Types of ICs – Digital & Analog ICs	1
3.2	Operational Amplifier: Ideal characteristics, inverting and non-inverting amplifier	1
3.3	Comparator circuit and applications.	1

3.4	Digital Circuits: Basic Boolean algebra laws and theorems, De-Morgan's theorem	1
3.5	Basic logic gates and Universal gates (with analogy)	1
3.6	Minimization of logic expressions using Boolean algebra and realization using gates.	1
<b>MODULE IV</b>		
4.1	Principle and block diagram of electronic instrumentation system	1
4.2	Sensors and Transducers: Active and Passive transducers-, photoelectric transducer (Photodiode, Solar Cell)	1
4.3	Piezoelectric transducer, accelerometer and their applications.	2
4.4	Force sensor (Strain gauge), Displacement sensor (LVDT) and their applications.	1
4.5	Temperature sensor (Thermistor), light sensor (LDR) and applications.	1
<b>MODULE V</b>		
5.1	Communication Systems: Introduction, need for modulation, frequency bands used for various communication systems.	1
5.2	Radio communication: principle of AM, FM, comparison of AM & FM.	1
5.3	Radio receiver: Block diagram of AM super heterodyne receiver.	1
5.4	Mobile Communication: Basic principles of cellular communications, principle and block diagram of GSM, concept of frequency reuse, hand off – soft and hard hand off.	2
5.5	Pulse Code Modulation, Various Digital Modulation Techniques-ASK, PSK, FSK	2
5.6	Basics of Networking, Network Topologies-Bus, Ring, Star and hybrid topology, Classifications of Computer Networks- LAN, MAN, WAN	1
<b>CO Assessment Questions</b>		
1	Perform a role play to illustrate the different current components in a pnp transistor.	
2	Illustrate the working of a full wave bridge rectifier. Compare any three parameters of a half wave and full wave rectifier using appropriate simulation tool and give the reason for selecting the parameters.	
3	Write any logic function, minimize it and simulate using appropriate tool. Selected function should be capable of illustrating minimization rules.	

4	Sketch an op-amp circuit for comparing the voltage levels of two distinct signals. Illustrate how this circuit can be used to detect the positive half cycle of an alternating sinusoidal waveform.
5	Differentiate between a sensor and transducer. Explain the working principle of a piezo electric transducer.
6	Perform a role play to illustrate the working principle of GSM.

<b>24ESP107</b>	<b>TECHNICAL ENGLISH FOR ENGINEERS</b>	<b>L</b>	<b>T</b>	<b>P</b>	<b>J</b>	<b>S</b>	<b>C</b>	<b>Year of Introduction</b>
		<b>2</b>	<b>0</b>	<b>2</b>	<b>0</b>	<b>4</b>	<b>3</b>	<b>2024</b>

**Preamble:** This course enables the students to use the basic skills of communication such as reading, listening, writing and speaking. The topics like Use of Language in communication, Oral Presentation, Interview Skills, Formal Writing, Reading Comprehension and Listening skills are covered in this course. The course helps the learners to communicate with group, face interviews and prepare technical documents in an effective manner.

**Prerequisite: NIL**

**Course Outcomes:** After the completion of the course the student will be able to

<b>CO 1</b>	Use vocabulary and language skills in professional communication. [Apply level]
<b>CO 2</b>	Demonstrate technical presentation and speaking skills. [Apply level]
<b>CO 3</b>	Make use of the interview skills in real life situation. [Apply level]
<b>CO 4</b>	Create professional and technical documents precisely. [Apply level]
<b>CO 5</b>	Use reading and listening techniques in an effective way. [Apply level]

**CO - PO MAPPING**

<b>CO</b>	<b>PO1</b>	<b>PO2</b>	<b>PO3</b>	<b>PO4</b>	<b>PO5</b>	<b>PO6</b>	<b>PO7</b>	<b>PO8</b>	<b>PO9</b>	<b>PO10</b>	<b>PO11</b>	<b>PO12</b>
<b>CO 1</b>								✓	✓	✓		✓
<b>CO 2</b>								✓	✓	✓		✓
<b>CO 3</b>								✓	✓	✓		✓
<b>CO 4</b>								✓		✓		✓
<b>CO 5</b>								✓	✓	✓		✓

**Assessment Pattern for Theory component**

<b>Bloom's Category</b>	<b>Continuous Assessment Tools</b>			<b>End Semester Examination</b>
	<b>Test 1</b>	<b>Test 2</b>	<b>Other tools</b>	
Remember	-	✓	✓	✓
Understand	-	✓	✓	✓
Apply	-	✓	✓	✓
Analyse			✓	
Evaluate			✓	
Create			✓	

**Assessment Pattern for Lab component**

<b>Bloom's Category</b>	<b>Continuous Assessment Tools</b>	
	<b>Class work</b>	<b>Test1</b>
Remember		
Understand	✓	✓
Apply	✓	✓

Analyse	✓	✓
Evaluate		
Create		

### Mark Distribution of CIA

Course Structure [L-T-P-J]	Attendance	Theory [L- T]			Practical [P]		Total Marks
		Assignment	Test-1	Test-2	Class work	Lab Exam/ Practice	
2-0-2-0	5	10	-	15	15	15	60

### Total Marks distribution

Total Marks	CIA (Marks)	ESE (Marks)	ESE Duration
100	60	40	2.5 Hours

### End Semester Examination [ESE]: Pattern

PATTERN	PART A	PART B	ESE Marks
PATTERN 2		2 questions will be given from each module, out of which 1 question should be answered. Each question can have a maximum of 2 sub divisions. Each question carries 8 marks. Marks: (5x 8 = 40 marks) Time: 2.5 hours	40
	Total Marks: 0	Total Marks: [5x8 = 40 marks]	

### SYLLABUS

#### **MODULE I: Use of Language in communication**

Significance of Technical communication- Technical vocabulary used in formal letters, emails, reports, misspelled words, synonyms, antonyms, and paraphrasing. Grammar- Subject-verb agreement, reported speech, active-passive voice, use of adjectives and adverbs, prepositions.

#### **MODULE II: Oral Presentation**

Voice Modulation, tone, Intonation, pronunciation, presentation skills, public speaking skills, Types of presentations, the use of visuals in presentation, debate, G.D., brainstorming, body language, and audience analysis.

#### **MODULE III: Interview Skills**

Interview skills: Objectives and types of interviews, preparing for interview, interview



etiquette, dress code, body language, online interview, panel interview, one-to-one interview, FAQ'S related to job interviews, and answering strategies.

#### **MODULE IV: Formal Writing**

Formal Writing: Letter- Formal, informal, and semi-formal. Email, Job application letters, C.V., Resume, and Biodata, minutes preparation, different types of reports, common errors in writing, use of sequence words, and Statement of purpose. Reference styling, IEEE format, bibliography, analytical and issue-based essay writing, plagiarism.

#### **MODULE V: Reading Comprehension and Listening skills**

Reading, comprehension, and summarizing: Reading Styles, speed reading, critical reading, reading and comprehending longer and shorter technical articles from journals and newspapers, SQ3R method, PQRS method, identifying transitions of text, note taking.

Listening skills: Active and Passive listening, listening for general content, listening for specific information, developing effective listening skills, barriers to effective listening, listening to longer technical talks and classroom lectures, TED talks, taking notes while listening.

#### **Text books / Reference books**

1. Meenakshi Raman and Sangeetha Sharma, Technical Communication: Principles and Practice, 3<sup>rd</sup> edition, Oxford University Press, 2015
2. Anderson, P.V, Technical Communication, Thomas Wadsworth, Sixth edition, New Delhi, 2007
3. English for Engineers and Technologists (Combined edition, Vol,1 and 2), Orient Blackswann 2010
4. Seely, John, The Oxford Guide to Writing and Speaking, Oxford university Press, 1997
5. Ganguly, Anand, Success in Interview, RPH, Fifth edition, 2006
6. Effective Communication Skills. Kul Bhushan Kumar, Khanna Book Publishing, 2022.
7. Practical English Usage. Michael Swan. OUP. 1995.
8. Remedial English Grammar. F.T. Wood. Macmillan.2007
9. On Writing Well. William Zinsser. Harper Resource Book. 2001
10. Study Writing. Liz Hamp-Lyons and Ben Heasley. Cambridge University Press. 2006.
11. Communication Skills. Sanjay Kumar and Pushplata. Oxford University Press. 2011.
12. Exercises in Spoken English. Parts. I-III. CIEFL, Hyderabad. Oxford University Press.

#### **NPTEL/SWAYAM Courses for reference:**

1. English Language for Competitive Exams Prof. Aysha Iqbal IIT Madras
2. Technical English for Engineers Prof. Aysha Iqbal IITM

<b>COURSE CONTENTS AND LECTURE SCHEDULE</b>		
No.		No. of Hours [35]
<b>MODULE 1</b>		<b>8 Hrs</b>
1.1	Introduction, misspelled words	1
1.2	Synonyms and antonyms	1
1.3	Technical vocabulary in email and letters and reports	1
1.4	Paraphrasing	1
1.5	Subject-verb agreement	1
1.6	Reported Speech	1
1.7	Active and passive voice	1
1.8	Preposition, use of adjectives and adverbs	1
<b>MODULE II</b>		<b>6 Hrs</b>
2.1	Presentation skills	1
2.2	Importance of voice modulation, tone, intonation	1
2.3	Use of visuals in presentation, public speaking skills	1
2.4	Debate and G.D – differences.	1
2.5	Body Language and audience analysis	1
2.6	Brainstorming	1
<b>MODULE III</b>		<b>6 Hrs</b>
3.1	Objectives of Interview, types of Interviews	1
3.2	Preparation strategies for attending interview	1
3.3	Dress code and body language for interviews.	1
3.4	Interview Etiquettes	1
3.5	FAQs related to job interviews	1
3.6	Strategies for different types of interviews- Online interview, panel interview, one-to-one interview.	1
<b>MODULE IV</b>		<b>9 Hrs</b>
4.1	Formal, informal, and semi-formal letters	1
4.2	Email Writing and etiquette	1
4.3	Application letter, email.	1
4.4	C.V, Resume, Biodata – introduction and differences	1
4.5	C.V, Resume, Biodata writing process	1
4.6	Minutes preparation	1
4.7	Types of reports, use of sequence words	1
4.8	Statement of purpose, referencing style, bibliography.	1
4.9	IEEE format, plagiarism, issue-based essay writing.	1

<b>MODULE V</b>		<b>6 Hrs</b>
5.1	Reading Styles	1
5.2	Speed reading, critical reading	1
5.3	Comprehending longer and shorter technical articles from journals and newspaper	1
5.4	Reading methods, SQ3R and PQRS methods, identifying transitions in text	1
5.5	Active and Passive listening, Listening for general and specific content	1
5.6	Barriers to effective listening.	1

### **LESSON PLAN FOR LAB COMPONENT**

<b>No.</b>	<b>Topic</b>	<b>No. of Hours</b>	<b>Experiment</b>
1	Difference between literary and technical writing style	1	Writing exercises for both creative and technical writing that highlight Grammatical and linguistic differences between two.
2	Presentation	3	Create and present a PPT based on a given topic.
3	Group Discussion	2	Group discussion and debate based on a given topic.
4	Voice modulation, tone, and intonation	1	Analyze a given video presentations of speakers, technocrats, and management experts based on the concepts learned.
5	Effects of body language in presentation and public speaking.		
6	Interview Skills	1	Mock Panel Interview
7	Interview body language and etiquette	1	Analyze the given videos of both mock/ original job interviews based on the concepts learned.
8	Report writing	1	Writing exercises for different types of reports.
10	Comprehension exercise	2	Comprehend articles from scientific journals.
			Comprehend articles from newspapers.
11	Listening exercise – 1	1	Answering the Question / Note Making from TED talks.

12	Listening exercise – 2	1	Write the subtitles and lyrics from the English movie clips and songs provided
----	------------------------	---	--

<b>CO Assessment Questions</b>	
CO1	<ol style="list-style-type: none"> <li>Find the word with the correct spelling from the following list a) Accommodate b) Acommodate c) Accomadate d) Acomodate</li> <li>Which word in the following list is closest to the meaning of the word 'gloomy' a) Happy b) Sad c) Enthralled d) elated.</li> <li>Select the most suitable preposition for the sentence from the following list I was born _____ May (in / on / at) My friend lives _____ Beach Road (in/on/at)</li> </ol>
CO2	<ol style="list-style-type: none"> <li>What is the significance of body language in presentation?</li> <li>Explain the strategies to improve your Debate skills.</li> <li>How important is visual aid for presentations?</li> <li>As a student who presented a slide presentation, how will you respond to a disturbed audience?</li> </ol>
CO3	<ol style="list-style-type: none"> <li>Explain the significance of non- verbal communication in interviews.</li> <li>What are the differences that you will make while attending an online interview instead of an off line interview.</li> <li>How will you politely respond to a question asked to you in an interview to which you don't know the answer?</li> <li>As a viewer of the mock interview conducted in the class, what were the do's and don'ts to be followed in an interview.</li> </ol>
CO4	<ol style="list-style-type: none"> <li>What are the differences between a C.V., Resume and Biodata?</li> <li>Write an email to the manager of ABC Technologies asking for an opportunity to be included in their internship program</li> <li>What are the different types of reports?</li> </ol>
CO5	<ol style="list-style-type: none"> <li>What is critical reading? What are the advantages of critical reading over speed reading?</li> <li>Write down the lyrics of the song as you hear it.</li> <li>Write a synopsis of the journal article that you just read.</li> </ol>

<b>24MCP110</b>	<b>IDEA LAB</b>	<b>L</b>	<b>T</b>	<b>P</b>	<b>J</b>	<b>S</b>	<b>C</b>	<b>Year of Introduction</b>
		<b>2</b>	<b>0</b>	<b>2</b>	<b>0</b>	<b>4</b>	<b>1</b>	<b>2024</b>

**Preamble:** This course enables the learners to understand the concepts of design, development and documentation tools under various domains in engineering. The various topics covered in this course are concepts of Microcontroller Programming, PCB Designing and Prototyping, Modelling, Slicing, Cutting, Routing, and Documentation & version control Tools. This course helps the students to design and develop real life applications using multidisciplinary engineering aspects.

**Prerequisite:** NIL

**Course Outcomes:** After the completion of the course the student will be able to

**CO 1** Develop project using appropriate Microcontroller Programming languages. [Apply level]

**CO 2** Develop product using PCB Design and Prototyping concepts. [Apply level]

**CO 3** Create 2D and 3D models using appropriate tools. [Apply level]

**CO 4** Create electronic documentation for the system/project using appropriate tools. [Apply level]

**CO 5** Build useful and standalone system/ project with enclosures. [Apply level]

#### CO - PO MAPPING

CO	PO1	PO2	PO3	PO4	PO5	PO6	PO7	PO8	PO9	PO10	PO11	PO12
CO 1	✓	✓	✓	✓	✓	✓		✓	✓			✓
CO 2	✓	✓	✓	✓	✓	✓		✓	✓			✓
CO 3	✓	✓	✓	✓	✓	✓		✓	✓			✓
CO 4	✓	✓	✓	✓	✓			✓	✓	✓		✓
CO 5	✓	✓	✓	✓	✓	✓		✓	✓			✓

#### Assessment Pattern for Lab component

Bloom's Category	Continuous Assessment Tools	
	Class work	Test1
Remember		
Understand	✓	✓
Apply	✓	✓
Analyse	✓	✓
Evaluate	✓	
Create	✓	

#### Assessment Pattern for Project component

Bloom's Category	Continuous Assessment Tools		
	Evaluation 1	Evaluation 2	Report
Remember			
Understand	✓	✓	
Apply	✓	✓	
Analyse	✓	✓	

Evaluate		✓	
Create		✓	

**Mark Distribution of CIA**

Course Structure [L-T-P-J]	Attendance	Theory [L- T]		Practical [P]		Total
		Assignment	Test-1	Lab work	Test 2	
<b>2-0-2-0</b>	5	10	20	*45	20	<b>100</b>

\* As part of their lab work, students are required to submit a Micro project. The total marks for the lab component in the idea lab are calculated as a cumulative sum of the continuous assessment of lab work, which carries 20 marks, and the micro project evaluation, which carries 25 marks. The micro project evaluation is further divided into three components: 10 marks for the intermediate evaluation of the micro project, 10 marks for the project presentation and demonstration, and 5 marks for the micro project report submitted at the end of the semester.

**Total Marks distribution**

Total Marks	CIA (Marks)	ESE (Marks)	ESE Duration
100	100	-	-

**SYLLABUS**

**MODULE I: Introduction Microcontroller Programming**

Introduction to micro controller and embedded systems, Introduction to Arduino and its IDE Concept of digital and analog ports, registers, memory, timer, counter.  
 Embedded C programming: Arduino data types, operators, Array, Loop, Functions.

**MODULE II: Microcontroller Programming**

Embedded C programming: Working with Serial Monitor, Pins Configuration as INPUT/OUTPUT, digitalRead(), digitalWrite(), Interrupts, delay(), Pull-up resistors.  
 Interfacing a 8-bit LCD to Arduino, Running message display.  
 Sensor/Actuator Interface: Temperature Sensor, LDR based sensor, IR and Ultrasonic sensors, Relay, LED, Servomotor.

**MODULE III: PCB Designing and Prototyping**

Introduction: PCB, pads, track, SMD, through hole, via and its Design rules. Design any two simple circuit using Easy EDA/Eagle/Flat CAM, Routing and Generating GERBER file.  
 PCB Chemical etching Vs Milling techniques, PCB Chemical Etching/Milling

**MODULE IV: << Modelling, Slicing, Cutting, Routing >>**

3D modeling, Slicing, 3 D printing, 2D design using Inkscape, Laser CAD, Laser Cutting, 2D modelling, CNC Routing, CNC Routing, Tool familiarization

**MODULE V: << Documentation and version control Tools >>**

Familiarization of Google Docs, Google Sheets, Google Slides, Google Drawings, Google Forms Google Sites, Creating Google sheets, Google slides, Google forms and Google sites

Doxygen – Overview, Installation, Getting started, Documenting the code, Markdown support, Lists, Grouping, Including formulas, Including tables, Graphs and diagrams, Preprocessing, Output Formats, Searching, Customizing the output, Custom Commands, Linking to external documentation,

### **Reference books**

1. AICTE's Prescribed Textbook: Workshop / Manufacturing Practices (with Lab Manual), Khanna Book Publishing
2. All-in-One Electronics Simplified, A.K. Maini; 2021. ISBN-13: 978-9386173393, Khanna Book Publishing Company, New Delhi.
3. Simplified Q&A - Data Science with Artificial Intelligence, Machine Learning and Deep Learning, Rajiv Chopra, ISBN: 978-9355380821, Khanna Book Publishing Company, New Delhi.
4. 3D Printing & Design, Dr. Sabrie Soloman, ISBN: 978-9386173768, Khanna Book Publishing Company, New Delhi.
5. The Big Book of Maker Skills: Tools & Techniques for Building Great Tech Projects. Chris Hackett. Weldon Owen; 2018. ISBN-13: 978-1681884325.
6. The Total Inventors Manual (Popular Science): Transform Your Idea into a Top-Selling Product. Sean Michael Ragan (Author). Weldon Owen; 2017. ISBN-13: 978-1681881584.
7. Make: Tools: How They Work and How to Use Them. Platt, Charles. Shroff/Maker Media. 2018. ISBN-13: 978-9352137374
8. The Art of Electronics. 3rd edition. Paul Horowitz and Winfield Hill. Cambridge University Press. ISBN: 9780521809269
9. Practical Electronics for Inventors. 4th edition. Paul Sherz and Simon Monk. McGraw Hill. ISBN-13: 978-1259587542
10. Encyclopedia of Electronic Components (Volume 1, 2 and 3). Charles Platt. Shroff Publishers. ISBN-13: 978-9352131945, 978-9352131952, 978-9352133703
11. Building Scientific Apparatus. 4th edition. John H. Moore, Christopher C. Davis, Michael A. Coplan and Sandra C. Greer. Cambridge University Press. ISBN-13: 978-0521878586
12. Programming Arduino: Getting Started with Sketches. 2nd edition. Simon Monk. McGraw Hill. ISBN-13: 978-1259641633
13. Make Your Own PCBs with EAGLE: From Schematic Designs to Finished Boards. Simon Monk and Duncan Amos. McGraw Hill Education. ISBN-13: 978-1260019193.
14. Pro GIT. 2nd edition. Scott Chacon and Ben Straub. A press. ISBN-13: 978-1484200773
15. Venuvinod, PK., MA. W., Rapid Prototyping – Laser Based and Other Technologies, Kluwer.

16. Ian Gibson, David W Rosen, Brent Stucker., “Additive Manufacturing Technologies: Rapid Prototyping to Direct Digital Manufacturing”, Springer, 2010

17. Chapman W.A.J, “Workshop Technology”, Volume I, II, III, CBS Publishers and distributors, 5<sup>th</sup> Edition,2002

<b>COURSE CONTENTS AND LECTURE SCHEDULE</b>		
No.		No. of Hours [19]
<b>MODULE 1</b>		
1.1	Introduction to micro controller and embedded systems,	1
1.2	Introduction to Arduino and its IDE Concept of digital and analog ports, registers, memory, timer, counter.	1
1.3	Embedded C programming: Arduino data types, operators, Array, Loop, Functions.	1
<b>MODULE II</b>		
2.1	Embedded C programming: Working with Serial Monitor, Pins Configuration as INPUT/OUTPUT.	1
2.2	Embedded C programming: digitalWrite(), digitalRead(), Interrupts, delay(), Pull-up resistors.	1
2.3	Embedded C programming: Interfacing a 8 bit LCD to Arduino, Running message display	
2.4	Sensor/Actuator Interface: Temperature Sensor, LDR based sensor, IR and Ultrasonic sensors, Relay, LED, Servomotor Introduction: PCB, pads, track, SMD, through hole, via and its Design rules. Routing and Generating GERBER file	1
<b>MODULE III</b>		
3.1	Introduction: PCB, pads, track, SMD, through hole, via and its Design rules.	1
3.2	Routing and Generating GERBER file	1
3.3	PCB Chemical etching Vs Milling techniques, PCB Chemical Etching/Milling	1
<b>MODULE IV</b>		
4.1	3D modeling, Slicing, 3 D printing	1
4.2	2D design using Inkscape, Laser CAD	
4.3	Laser Cutting, 2D modelling, CNC Routing,	1
4.4	CNC Routing Tool familiarisation	
<b>MODULE V</b>		
5.1	Familiarization of Google Docs, Google Sheets, Google Slides,	1
5.2	Google Drawings, Google Forms Google Sites	1
5.3	Doxygen – Overview, Installation, Getting started, Documenting the code, Markdown support, Lists,	1



5.4	Doxygen - Grouping, including formulas, Including tables, Graphs and diagrams, Preprocessing	1
5.5	Doxygen – Output Formats, Searching, Customizing the output, Custom Commands, Linking to external documentation	1

### LESSON PLAN FOR LAB COMPONENT

No.	Topic	No. of Hours	Experiment
1	Introduction to micro controller and embedded systems,	3	Simple Embedded C programs: Arduino data types, operators, Array, Loop, Functions
2	Introduction to Arduino and its IDE Concept of digital and analog ports, registers, memory, timer, counter.		
3	Embedded C programming: Arduino data types, operators, Array, Loop, Functions.		
4	Serial Monitor, Pins Configuration as INPUT/OUTPUT, digitalRead(), digitalWrite(), Interrupts, delay(), Pull-up resistors.	5	Embedded C programs to working with Serial Monitor, Pins Configuration as INPUT/OUTPUT, digitalRead(), digitalWrite(), Interrupts, delay(), Pull-up resistors. Implement : Water level control system. Distance measurement and Display unit. Home Automation system.
5	Introduction: PCB, pads, track, SMD, through hole, via and its Design rules.	6	Design any two simple circuit using Easy EDA/ Eagle/ FlatCAM Routing and Generating GERBER file
6	PCB Chemical etching Vs Milling techniques	2	Experiments with PCB Chemical Etching/Milling
7	3D modeling, Slicing, 3 D printing, 2D design using Inkscape, Laser CAD, Laser Cutting, 2D modelling, CNC Routing, CNC Routing, Tool familiarization	14	Machining of 3D geometry on soft material such as soft wood or modelling wax, 3D scanning of computer mouse geometry surface. 3D printing of scanned geometry. 2D profile cutting of press fit box/casing in acrylic (3 or 6

			mm thickness)/cardboard,D profile cutting on plywood /MDF (6-12 mm) for press fit designs
8	Familiarization of Google Docs, Google Sheets, Google Slides, Google, Drawings, Google Forms Google Sites	2	Exercise for creating Google sheets, Google slides, Google forms and Google sites
9	Doxygen – Overview, Documenting the code, Markdown support, Lists, Grouping, Including formulas, Including tables, Graphs and diagrams, Preprocessing, Output Formats, Searching, Customizing the output, Custom Commands, Linking to external documentation.	4	Doxygen –Installation, Getting started Document the programs created for Raspberry pi and Arduino using Doxygen
	Familiarisation of Version control tools - GIT and GitHub	4	At least two programs in programming exercises must be done using GitHub

24HUL111	DESIGN THINKING	L	T	P	J	S	C	Year Of Introduction
		0	0	2	0	2	1	2024

**Preamble:** This course enables the students to understand the fundamentals of design thinking and use the basic tools, techniques & approaches. The various topics covered in this syllabus are: An Insight to Learning, Basics of design thinking, Being ingenious and fixing problems, Prototype and testing, Design thinking and customer centricity. This course helps the learners to apply design thinking approach while developing practical solutions for real world problems.

**Prerequisite:** NIL

**Course Outcomes:** After the completion of the course the student will be able to

<b>CO1</b>	Compare and classify the various learning styles and memory techniques and apply them in their engineering education.
<b>CO2</b>	Analyze emotional experience and inspect emotional expressions to better understand users while designing innovative products
<b>CO3</b>	Develop new ways of creative thinking and learn the innovation cycle of design thinking process for developing innovative products.
<b>CO4</b>	Propose solutions for real-world engineering problems by applying creative design thinking
<b>CO5</b>	Perceive individual differences and its impact on everyday decisions thereby lead and/or perform in a design team
<b>CO6</b>	Perform customer centric designing by intelligently accommodating customer requirements/challenges so as to eventually improve customer experience
<b>CO7</b>	Develop new designs for simple products using bio-mimicry to bring out new nature inspired designs
<b>CO8</b>	Solve practical engineering problem through innovative product design and creative solution

**CO - PO MAPPING**

CO	PO1	PO2	PO3	PO4	PO5	PO6	PO7	PO8	PO9	PO10	PO11	PO12
CO1	✓							✓	✓			✓
CO2				✓		✓		✓	✓	✓		✓
CO3	✓	✓	✓	✓		✓		✓	✓	✓		✓
CO4								✓	✓	✓		✓
CO5						✓		✓	✓	✓		✓
CO6	✓	✓	✓			✓		✓	✓	✓		✓
CO7	✓	✓	✓	✓		✓		✓	✓	✓		✓

**Assessment Pattern**

Bloom's Category	Continuous Assessment Tools	
	Class work	Test 1
Remember		
Understand	✓	✓
Apply	✓	✓

Analyse	✓	✓
Evaluate	✓	
Create	✓	

#### Mark Distribution of CIA

Course Structure [L-T-P-J]	Attendance	Class work	Lab Exam/ Presentation	Total Marks
0-0-2-0	5	35	10	50

#### Total Mark distribution

Total Marks	CIA (Marks)	ESE (Marks)	ESE Duration
50	50	-	-

#### SYLLABUS

**An Insight to Learning** - Understanding the Learning Process, Kolb's Learning Styles, Assessing and Interpreting. Remembering Memory - Understanding the Memory process, Problems in retention, Memory enhancement techniques, Emotions: - Experience & Expression, Understanding Emotions- Experience & Expression, Assessing Empathy, Application with Peers.

**Basics of Design Thinking** - Definition of Design Thinking, Need for Design Thinking, Objective of Design Thinking, Concepts & Brainstorming, Stages of Design Thinking Process (explain with examples) – Empathize, Define, Ideate, Prototype, Test Being Ingenious & Fixing Problem - Understanding Creative thinking process, Understanding Problem Solving, Testing Creative, Problem Solving, Process of Product Design - Process of Engineering Product Design, Design Thinking Approach, Stages of Product Design, Examples of best product designs and functions, Assignment – Engineering Product Design

**Prototyping & Testing** - What is Prototype? Why Prototype? Rapid Prototype Development process, Testing, Sample, Example, Test Group Marketing, Celebrating the Difference - Understanding Individual differences & Uniqueness, Group Discussion and Activities to encourage the understanding, acceptance and appreciation of Individual differences

**Design Thinking & Customer Centricity** - Practical Examples of Customer Challenges, Use of Design Thinking to Enhance Customer Experience, Parameters of Product experience, Alignment of Customer Expectations with Product Design, Feedback, Re-Design & Re-Create Feedback loop, Focus on User Experience, Address “ergonomic challenges, User focused design, rapid prototyping & testing, final product, Final Presentation – “Solving Practical Engineering Problem through Innovative Product Design & Creative Solution”.

#### Text books

1. YousefHaik, Sangarappillai Sivaloganathan, Tamer M. Shahin, Engineering Design Process, Cengage Learning 2003, Third Edition, ISBN-10: 781305253285,
2. Voland, G., Engineering by Design, Pearson India 2014, Second Edition, ISBN 9332535051

### Reference books

1. Philip Kosky, Robert Balmer, William Keat, George Wise, Exploring Engineering, Fourth Edition: An Introduction to Engineering and Design, Academic Press 2015, 4th Edition, ISBN: 9780128012420.
2. Clive L. Dym, Engineering Design: A Project-Based Introduction, John Wiley & Sons, New York 2009, Fourth Edition, ISBN: 978-1-118-32458-5
3. Nigel Cross, Design Thinking: Understanding How Designers Think and Work, Berg Publishers 2011, First Edition, ISBN: 978-1847886361
4. Pahl, G., Beitz, W., Feldhusen, J., Grote, K.-H., Engineering Design: A Systematic Approach, Springer 2007, Third Edition, ISBN 978-1-84628-319-2

### Reference materials

1. Design Thinking for Strategic Innovation: What They Can't Teach You at Business or Design School, <https://www.amazon.in/Design-Thinking-Strategic-Innovation-Business/dp/8126572698/>
2. Don't Make Me Think, Revisited: A Common Sense Approach to Web Usability (3rd Edition), <https://www.amazon.in/Dont-Make-Think-Revisited-Usability/dp/9332542864/>
3. Design as Art (Penguin Modern Classics) <https://www.amazon.in/Design-Art-Penguin-Modern-Classics/dp/0141035811/>
4. Hooked: How to Build Habit-Forming Products ₹ 368 <https://www.amazon.in/Hooked-How-Build-Habit-Forming-Products/dp/0241184835/>
5. Emotional Design <https://www.amazon.in/Emotional-Design-Don-Norman/dp/0465051367/>
6. Value Proposition Design: How to Create Products and Services Customers Want <https://www.amazon.in/Value-Proposition-Design-Products-Customers/dp/8126553073/>
7. The Art Of Creative Thinking , <https://www.amazon.in/Art-Creative-Thinking-Rod-Judkins/dp/1444794485/>
8. Lateral Thinking: A Textbook of Creativity, <https://www.amazon.in/Lateral-Thinking-Creativity-Edward-Bono/dp/0241257549/>
9. This is Service Design Thinking: Basics, Tools, Cases , <https://www.amazon.in/This-Service-Design-Thinking-Basics/dp/1118156307/>
10. The Design of Business, <https://www.amazon.in/Design-Business-Roger-L-Martin/dp/1422177807/>
11. The Design Thinking Playbook: Mindful Digital Transformation of Teams, Products, Services, Businesses, and Ecosystems <https://www.amazon.in/Design-Thinking-Playbook-Transformation-Businesses/dp/1119467470/>
12. Thinking, Fast and Slow (Penguin Press Non-Fiction) <https://www.amazon.in/Thinking-Fast-Penguin-Press-Non-Fiction/dp/0141033576/>

## LIST OF EXPERIMENTS

No.	Experiments
1	<p>Topic: An Insight to Learning, Remembering Memory, Emotions: Experience &amp; Expression.</p> <ol style="list-style-type: none"> <li>1. Group discussion/ Video presentation that addresses the concepts that shall be conveyed through the following questions.               <ol style="list-style-type: none"> <li>a) How learning happens?</li> <li>b) What are the main components of Kolb's cycle of experiential learning and examples?</li> <li>c) What is the memory process?</li> <li>d) What are the different memory enhancement techniques?</li> <li>e) What is the need for understanding emotions?</li> <li>f) Identify the different ways of assessing empathy and applying them among peers.</li> <li>g) Assume you got a chance to teach capitals of different countries in a UKG class. Illustrate what different memory enhancement techniques you will use through a role play.</li> </ol> </li> <li>2. Each team member of the group lists your positive and negative emotions. Among team members, discuss how each one of you manage each emotions. (Like finding happiness, escaping from sadness, managing anger, Facing fear, Overcoming shame etc you can put more questions). After the discussion did you get some technique to manage your emotion in a better way?</li> </ol>
2	<p>Topic: - An Approach to Introduce and Instill Design Thinking. – Class discussion based on the following questions and write down the conclusion in Work Book.</p> <ol style="list-style-type: none"> <li>a) What do you mean by designing something? What is design thinking and why it is needed?</li> <li>b) What are the different stages of design thinking process?</li> <li>c) How does the design thinking approach help engineers in creating innovative and efficient designs?</li> <li>d) How can the engineers arrive at better designs utilizing the iterative design thinking process (in which knowledge acquired in the later stages can be applied back to the earlier stages)?</li> <li>e) Describe the design thinking process using appropriate examples.</li> </ol>
3	<p>Topic: - Activities on becoming Ingenious to Apply Design Thinking to Solve Real-world Problems.</p> <p>Take up a real-world problem and apply creative thinking design to solve them. Make a video presentation based on your work that shall include the answer to following questions.</p> <ol style="list-style-type: none"> <li>a) What is creative thinking process?</li> <li>b) How can you describe the process of problem solving with examples?</li> </ol>

	<ul style="list-style-type: none"> <li>c) How creative thinking process helps in problem solving?</li> <li>d) How to test the efficacy of creative problem solving process?</li> </ul>
4	<p>Topic :- Perform Designing of an Innovative Product-</p> <ul style="list-style-type: none"> <li>i) Perform group discussion on following points <ul style="list-style-type: none"> <li>a) How is engineering product design different from other kinds of design?</li> <li>b) Where and when do engineers perform product design?</li> <li>c) What are the different stages of product design?</li> <li>d) What are the different examples for best product designs and functions?</li> </ul> </li> <li>ii) Based on the concepts learned, design an innovative product in your mind and give presentation.</li> </ul>
5	<p>Topic: - Learn the Prototype Development Process and Testing. Illustrate the following concepts using appropriate tools.</p> <ul style="list-style-type: none"> <li>a) How to predict whether the design will function well or not?</li> <li>b) How do mathematics and physics become a part of the design process?</li> <li>c) What is Prototype? Why it is needed?</li> <li>d) What is rapid prototype development process?</li> <li>e) List the different methods in which the prototype of a product can be generated and tested.</li> </ul>
6	<p>Topic- Active Learning the Process of Divergent-Convergent Thinking and Designing in a Team:</p> <ol style="list-style-type: none"> <li>1. Perform group discussion and/or other activities within a design team to refine and narrow down to the 'best design'. Create a report which specifies, how you identified and managed the following questions during the design. <ul style="list-style-type: none"> <li>a) Describe how to create a number of possible designs and then how to refine and narrow down to the 'best design'?</li> <li>b) Why differences and uniqueness of individuals arise while designing in a team?</li> <li>c) How to manage conflicts in a design team?</li> <li>d) What is the need for different ways for communicating any design such as graphical, oral, written, presentation, models, prototypes, and so on?</li> </ul> </li> </ol>
7	<p>Topic: - End User Feedback to Improve Design Synthesize End User Feedback to Improve Design Solution you identified in the exercise number 6.</p>
8	<p>Topic: - Develop Nature-inspired Designs utilizing Bio-mimicry, aesthetic , ergonomic and life cycle design approach:</p> <ul style="list-style-type: none"> <li>i) Class discussion to understand the following concepts <ul style="list-style-type: none"> <li>a) What is the significance of Modular Design, Life Cycle Design Approaches in Design?</li> </ul> </li> </ul>

	<ul style="list-style-type: none"> <li>b) How does the intelligence in nature inspire engineering designs? Give examples</li> <li>c) How do aesthetic and ergonomic challenges modify designs?</li> <li>d) How do concepts like value engineering, concurrent engineering and reverse engineering influence engineering designs?</li> </ul> <p>ii) Based on the understanding you acquired through discussion develop new designs for simple products using bio-mimicry so as to bring out new nature inspired designs.</p>
<p>9</p>	<p>Topic: - Use Feedback to Improve Designs through Re-Design and Re-create.</p> <p>Get feedback of your any one of the earlier design exercises from the rest of the student groups and redesign accordingly. Also</p> <ul style="list-style-type: none"> <li>i) Answer the following questions <ul style="list-style-type: none"> <li>a) How feedbacks can improve designs? How user experience helps the re-design?</li> <li>b) What is a typical feedback loop in design process?</li> <li>c) What is user focused design?</li> <li>d) What is the role of rapid prototyping &amp; testing in developing the final design of products?</li> </ul> </li> <li>ii) Make a presentation to show the process of redesigning of an existing product based on feedbacks.</li> </ul>
<p>10</p>	<p>Topic: - Applications of Design Thinking</p> <p>Make presentation to illustrate that it is possible to provide innovative solutions for practical problems through Design Thinking</p>



**BRANCH SPECIFIC**  
**2 CREDIT COURSES**  
**(SEMESTER I)**

<b>24ESL107</b>	<b>APPLICATION DEVELOPMENT LAB</b>	<b>L</b>	<b>T</b>	<b>P</b>	<b>J</b>	<b>S</b>	<b>C</b>	<b>Year of Introduction</b>
		<b>0</b>	<b>0</b>	<b>2</b>	<b>0</b>	<b>2</b>	<b>1</b>	<b>2024</b>

**Preamble:** This course enables the learners with or without a Computer Science background to overcome their phobia towards the programming courses and blossom in the field of Computer Science by familiarizing themselves with the fundamentals in the designing of responsive web pages using various properties of HTML and CSS through hands-on training. This course covers the basics of HTML-Tags, Images, Hyperlinks, Lists, Frameset and Form Controls to design webpages, Styling of Webpages using Cascading Style Sheet (CSS) and the features of Responsive CSS bootstrap framework which helps the students to design and develop web-based solutions for real world problems.

**Prerequisite: Nil**

**Course Outcomes:** After the completion of the course the student will be able to

<b>CO1</b>	Explain basic HTML tags for the design of web pages.
<b>CO2</b>	Design professional document using Cascaded Style Sheets.
<b>CO3</b>	Apply the Knowledge of HTML, CSS to develop static webpages for a given scenario.
<b>CO4</b>	Describe the features of Responsive CSS Bootstrap Framework.

#### CO - PO MAPPING

CO	PO1	PO2	PO3	PO4	PO5	PO6	PO7	PO8	PO9	PO10	PO11	PO12
<b>CO1</b>	✓	✓			✓			✓				✓
<b>CO2</b>	✓	✓	✓		✓			✓	✓			✓
<b>CO3</b>	✓	✓	✓		✓			✓	✓			✓
<b>CO4</b>	✓	✓						✓				✓

#### Assessment Pattern

Bloom's Category	Continuous Assessment Tools	
	Class work	Test1
Remember		
Understand	✓	✓
Apply	✓	✓
Analyse	✓	✓
Evaluate	✓	
Create	✓	

#### Mark Distribution of CIA

Course Structure [L-T-P-J]	Attendance	Class work	Lab Exam	Total Marks
<b>0-0-2-0</b>	<b>5</b>	<b>35</b>	<b>10</b>	<b>50</b>

<b>Total Mark distribution</b>			
<b>Total Marks</b>	<b>CIA (Marks)</b>	<b>ESE (Marks)</b>	<b>ESE Duration</b>
<b>50</b>	<b>50</b>	<b>-</b>	<b>-</b>

### **SYLLABUS- DETAILS OF EXPERIMENTS**

Familiarize the concepts and features associated with web, Basic concepts in HTML and designing of simple web pages using HTML Tags, Images, Hyperlinks, List, Tables, Frame set and Form controls, Format the style of web pages using Cascading Style sheets and explore the basic concept of Bootstrap responsive framework.

#### **Text books**

1. Robert. W. Sebesta, “Programming the World Wide Web”, Fourth Edition, Pearson Education, 2007.

#### **Reference books**

1. Deitel, Goldberg, “Internet & World Wide Web How To Program”, Third Edition, Pearson Education, 2006.
2. Jeffrey C. Jackson, “Web Technologies–A Computer Science Perspective”, Pearson Education, 2006.
3. Marty Hall and Larry Brown, “Core Web Programming” Second Edition, Volume I and II, Pearson Education, 2001.

### **LIST OF EXPERIMENTS**

<b>No.</b>	<b>Experiments</b>
<b>I</b>	Familiarize the concepts and features associated with web.
<b>II</b>	<b>HTML Basics- Tags, Images, Hyperlinks</b>
	(i) (a) Create an HTML document including your name, address, e-mail address, Department, Semester and College. This document must use several headings and <em>, <strong>, <hr />, <p>, and   tags. (b) Add your photo and at least one other image (of your friend, or pet) to the document created for Exercise (a). (c) Add a second document to the document created that describes part of your background, using background as the link content. This document should have a few paragraphs of your personal or professional history. (ii) Create an HTML page with 7 separate lines in different colors. State color of each line in its text. (iii) Create an HTML page containing the polynomial expression as

follows.

$$a_0 + a_1X + a_2X^2 + a_3 X_3$$

- (iv) Write a HTML program for demonstrating Hyperlinks.
  - a. Navigation from one page to another.
  - b. Navigation within the page.
- (v) Design an HTML page to put an image in Marquee.
- (vi) Create a Gallery page that contain
  - (a) At least 10 images with proper order.
  - (b) Every image must have alt attribute with proper meaningful text.
  - (c) Every image size should be as given below
    - (i) Width=25%
    - (ii) Height: 220(pixel)
- (ix) Create an HTML page with red background with a message “Warning” in large size blinking. Add scrolling text “Read the message” below it.

### HTML Lists

- (i) Create an HTML document that describes an unordered list of at least four states. Each element of the list must have a nested list of at least three cities in the state.
- (ii) (a) Create an HTML document that describes an ordered list of your five favorite movies.
  - (b) Modify the list of ii. (a) to add nested, unordered lists of at least two actors and/or actresses in your favorite movies
- (iii) Design an HTML page to display the following.

III

- Maharashtra
  - Pune
    - I. Dighi
    - II. Moshi
    - III. Shivajinagar
  - Mumbai
    - I. Santakruiz
    - II. Vikroli
    - III. Mumbra

- (iv) Write HTML code to generate following output.

- 1
- 2
  - 2.1
  - 2.2
- 3

(v) Design the following web pages using HTML

## HTML Cooking School

### Recipes

Since this is an HTML tutorial, all links go to the sponge recipe. Just thought I'd warn you.

- Cakes
  - [Plain Sponge](#)
  - [Chocolate Cake](#)
  - [Apple Tea Cake](#)
- Biscuits
  - [ANZAC Biscuits](#)
  - [Jam Drops](#)
  - [Melting Moments](#)
- Breads/quickbreads
  - [Damper](#)
  - [Scones](#)

## HTML Tables

**IV**

- (i) (a) Create an HTML document that describes a table with the following contents: The columns of the table must have the headings “Pine”, “Maple”, “Oak”, and “Fir”. The rows must have the labels “Average Height”, “Average Width”, “Typical Life Span”, and “Leaf Type”. You can make up the data cell values.
- (b) Modify the HTML document from i. (a) that adds a second-level column label, “Tree”, and a second-level row label, “Characteristics”.
- (ii) Design an HTML page to display your class time table using tables.
- (iii) Create an HTML document that defines a table with two levels of column labels: an overall label, “Meals”, and three secondary labels, “Breakfast”, “Lunch”, and “Dinner”. There must be two levels of row labels: an overall label, “Foods”, and four secondary labels, “Bread”, “Main Course”, “Vegetable”, and “Dessert”. The cells of the table must contain a number of grams for each of the food categories. Use row span and column span properties.

**V**

## HTML Frame set

- (i) Write an HTML Form to generate the following output

<b>First Frame: Name and address</b>		
<b>Second frame</b> Bulleled list of qualifications		<b>Third frame</b> Links to favourite sites
<b>Fourth frame</b> Scrolling message	<b>Fifth frame</b> Blinking reminders	<b>Sixth frame</b> Image

(ii) Write a HTML code to generate following output

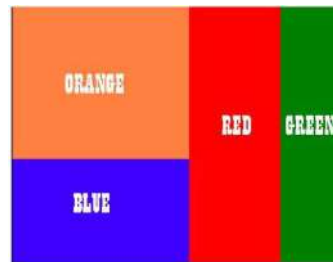

### HTML Form Controls

**VI**

- (i) Design an HTML document that has a form with the following controls:
- A **text box** to collect the user's name
  - Four checkboxes**, one each for the following items:
    - Four 100-watt light bulbs for \$2.39
    - Eight 100-watt light bulbs for \$4.29
    - Four 100-watt, long-life light bulbs for \$3.95
    - Eight 100-watt, long-life light bulbs for \$7.49
  - A **collection of three radio buttons** that are labeled as follows:
    - Visa
    - Master Card
    - Discover
  - Two Buttons** SAVE and CANCEL
- (ii) Design a static Student Registration Form including the personal details and educational qualifications.

### Cascading Style Sheets (CSS)

**VII**

- (i) Familiarize the need of CSS and its types for styling HTML web pages.
- (ii) Create HTML document that displays a table of football scores from a collegiate football conference in which the team names have one of the primary colors of their respective schools. The winning scores must appear larger and in a different font than the losing scores. The team names must be in a script font.

- (iii) Create an HTML document that describes nested ordered lists of cars. The outer list must have three entries: compact, midsize, and sports. Inside each of these three lists there must be two sublists of body styles. The compact- and midsize-car sublists are two door and four door; the sports-car sublists are coupe and convertible. Each body-style sublist must have at least three entries, each of which is the make and model of a particular car that fits the category. The outer list must use uppercase Roman numerals, the middle lists must use uppercase letters, and the inner lists must use Arabic numerals. The background color for the compact-car list must be pink; for the midsize-car list, it must be blue; for the sports-car list, it must be red. **Use the concept of Document & External style sheet.**
- (iv) Create an HTML document that has six short paragraphs of text that describe various aspects of the state in which you live. You must define three different paragraph styles, p1, p2, and p3. The p1 style must use left and right margins of 20 pixels, a background color of pink, and a foreground color of blue. The p2 style must use left and right margins of 30 pixels, a background color of black, and a foreground color of yellow. The p3 style must use a text indent of 1 centimeter, a background color of green, and a foreground color of white. The first and fourth paragraph must use p1, the second and fifth must use p2, and the third and sixth must use p3.
- (v) Create and test an HTML document that describes an unordered list of at least five popular books. The bullet for each book must be a small image of the book's cover. Find the images on the Web.
- (vi) Create an input with a visual, non-editable prefix.



- (vii) Create an HTML document that
  - (a) fades out the siblings of a hovered item.
  - (b) create a checkerboard background pattern and a zigzag background pattern
  - (c) create a zoom in zoom out animation

<b>VIII</b>	<b>Bootstrap Framework</b>
	Familiarization of Responsive CSS Frameworks – Bootstrap

## Webpage Creation (Use the concept of HTML, CSS, Bootstrap)

Design the following static web pages required for an online book store web site.

1. HOME PAGE
2. LOGIN PAGE
3. CATALOGUE PAGE
4. CART PAGE
5. REGISTRATION PAGE

**1. HOME PAGE:** The static home page must contain three frames.

**Top frame:** Logo and the college name and links to Home page, Login page, Registration page, Catalogue page and Cart page (the description of these pages will be given below).

**Left frame:** At least four links for navigation, which will display the catalogue of respective links. For e.g.: When you click the link “CSE” the catalogue for CSE Books should be displayed in the Right frame.

**Right frame:** The pages to the links in the left frame must be loaded here. Initially this page contains description of the web site.

IX

Logo	Web Site Name			
Home	Login	Registration	Catalogue	Cart
CSE ECE EEE CIVIL	Description of the Web Site			

**2. LOGIN PAGE:** This page looks like below:

Logo	Website Name			
Home	Login	Registration	Catalogue	Cart
TKM College of Engineering, Karicode, Kollam				
Computer Science & Engineering				
Login : <input type="text"/>				
Password: <input type="text"/>				
<input type="button" value="Submit"/>		<input type="button" value="Reset"/>		

### 3. CATALOGUE PAGE

The catalogue page should contain the details of all the books available in the web site. The details should contain the following.



1. Snap shot of Cover Page.
2. Author Name.
3. Publisher.
4. Price.
5. Add to cart button.

### CO Assessment Questions

Create the following web page using HTML coding.

1



- 2 Create web page that describes your Biodata. Use CSS for all style formatting.
- 3 Design a website for Online Railway Reservation Management System.
- 4 Describe how responsive website can be created using Bootstrap framework.

<b>24EST117</b>	<b>Basics of Electrical Engineering</b>	<b>L</b>	<b>T</b>	<b>P</b>	<b>J</b>	<b>S</b>	<b>C</b>	<b>Year of Introduction</b>
		<b>2</b>	<b>0</b>	<b>0</b>	<b>0</b>	<b>2</b>	<b>2</b>	<b>2024</b>

**Preamble:** To provide the students with a broad perspective of the field of Electrical Engineering. The course is designed to empower the students in solving simple electrical circuits. The course facilitates the students to learn about the generation and transmission of electrical power. The course introduces the operation and characteristics of DC and AC machines.

**Prerequisite:** Nil

**Course Outcomes:** After the completion of the course the student will be able to

**CO 1** Apply Electrical laws to compute different circuit parameters (Apply)

**CO 2** Identify the parameters of simple magnetic circuits (Understand)

**CO 3** Compute the parameters of simple A.C. electrical circuits (Understand)

**CO 4** Demonstrate the benefits of a three-phase system for industrial electrical applications (Analyze)

**CO 5** Understand the operation and characteristics of electrical machines (Understand)

#### CO - PO MAPPING

CO	PO1	PO2	PO3	PO4	PO5	PO6	PO7	PO8	PO9	PO10	PO11	PO12
CO 1	3	2										
CO 2	3	2								2		
CO 3	3	2										
CO 4	3								3	2		
CO 5	3								3			

#### Assessment Pattern

Bloom's Category	Continuous Assessment Tools			End Semester Examination
	Test 1	Test 2	Other tools	
Remember	✓	✓	✓	✓
Understand	✓	✓	✓	✓
Apply	✓	✓	✓	✓
Analyse				
Evaluate				
Create				

#### Mark Distribution of CIA

Course Structure [L-T-P-J]	Attendance	Theory [L- T]			Total Marks
		Assignment	Test-1	Test-2	
<b>2-0-0-0</b>	5	35	30	30	<b>100</b>

#### Total Mark distribution

Total Marks	CIA (Marks)	ESE (Marks)	ESE Duration
<b>100</b>	<b>100</b>	--	--

## **SYLLABUS**

### **MODULE I: D. C. Circuits**

D. C. Circuits: Ohm's Law and Kirchhoff's Laws; Loop current and Nodal voltage method; Steady state analysis with independent sources, Star-Delta conversion (Analysis of resistive networks only).

### **MODULE II: Magnetic circuits and Electromagnetism**

Magnetic circuits: MMF, field strength, flux density, reluctance, energy stored in magnetic circuits, Simple problems in series magnetic circuits.

Electromagnetism: Faradays Laws, Lenz's Law, Fleming's Rules, Statically and dynamically induced EMF; Concepts of self-inductance, mutual inductance and coefficient of coupling.

### **MODULE III: Single Phase AC systems**

Single Phase systems: Generation of sinusoidal voltage, RMS and Average value, form factor and peak factor of sinusoidal waveforms, Impedance of series circuits (RL, RC and RLC circuits). Phasor diagram of series circuits; Real, reactive and apparent power, power factor, Power triangle.

### **MODULE IV: Three Phase AC Systems**

Three Phase Systems: Generation of three phase voltages- advantages of three phase systems, star and delta connection, three wire and four wire systems, relation between line and phase voltages, line and phase currents. Expressions for power in three phase circuits; definition of phase sequence, balanced supply and balanced load; Relationship between line and phase values of balanced star and delta connections; Power in balanced three phase circuits.

Power transmission and distribution: Typical electrical power transmission scheme, need for high voltage transmission, primary and secondary transmission and distribution systems.

### **MODULE V: Fundamentals of Electrical Machines**

DC Machines: Working principle of DC motors - types of D.C. motors, characteristics (series and Shunt motors only) and applications - Necessity of a starter for DC motor. Transformer: Principle of operation and construction of single-phase transformers (core and shell types).

AC Machines - Three Phase Induction Motors: Concept of rotating magnetic field; Principle of operation, types and constructional features; Slip and its significance; Applications of squirrel cage and slip ring motors; Necessity of a starter, star-delta starter.

### **Text books**

1. Hughes, Electrical Technology, Pearson, 10th Edition, 2011.
2. Fitzgerald and Higginbotham, Basic Electrical Engineering, McGraw Hill Inc, 1981.
3. D.P. Kothari and I.J. Nagrath, Basic Electrical Engineering, 3rd Edition, TMH, 2009
4. Basic Electrical Engineering, D. C. Kulshreshtha, McGraw-Hill Education, Revised first edition, 2019

**Reference books**

1. Electrical Engineering Fundamentals, Vincent Del Toro, Prentice Hall, New Delhi.
2. Fundamentals of Electrical Engineering and Electronics, B.L. Theraja, S Chand and Company, Reprint Edition 2013.
3. Principles Electrical Engineering and Electronics, V.K Mehta, Rohit Mehta, S Chand and Company, 2nd edition, 2015.
4. M. S. Sukhija and T. K. Nagsarkar, Basic Electrical and Electronics Engineering, Oxford University Press, 2012.
5. S. B. Lal Seksena and Kaustuv Dasgupta, "Fundamentals of Electrical Engineering", Cambridge University Press.
6. NPTEL course on Basic Electrical Technology, Prof. G. D. Roy, IIT Kharagpur.

**COURSE CONTENTS AND LECTURE SCHEDULE**

No.		No. of Hours [23 Hrs]
<b>MODULE I</b>		
1.1	Ohm's Law and Kirchhoff's Laws; Loop current Method	1
1.2	Nodal voltage method; Steady state analysis with independent sources	1
1.3	Numerical problems	1
1.4	Star-Delta conversion (Analysis of resistive networks only).	1
<b>MODULE II</b>		
2.1	MMF, field strength, flux density, reluctance, energy stored in magnetic circuits	1
2.2	Simple problems in magnetic circuits	1
2.3	Faradays Laws, Lenz's Law, Fleming's Rules, Statically and dynamically induced EMF	1
2.4	Concepts of self-inductance, mutual inductance and coefficient of coupling	1
<b>MODULE III</b>		
3.1	Generation of sinusoidal voltage	1
3.2	RMS and Average value, form factor and peak factor of sinusoidal waveforms	1
3.3	Impedance of series circuits (RL, RC and RLC circuits). Phasor diagram of series circuits;	1
3.4	Real, reactive and apparent power, power factor, Power triangle	1
3.5	Numerical problems	1

<b>MODULE IV</b>		
4.1	Generation of three phase voltages- advantages of three phase systems, star and delta connection, three wire and four wire system	1
4.2	Relation between line and phase voltages, line and phase currents. Expressions for power in balanced three phase circuits	1
4.3	Definition of phase sequence, balanced supply and balanced load; Relationship between line and phase values of balanced star and delta connections	1
4.4	Numerical problems	1
4.5	Typical electrical power transmission scheme, need for high voltage transmission, primary and secondary transmission and distribution systems.	1
<b>MODULE V</b>		
5.1	Working principle of DC motors - Types of D.C. motors, characteristics (series and Shunt motors only) and applications; Necessity of a starter for DC motor	1
5.2	Principle of operation and construction of single-phase transformers (core and shell types)	1
5.3	Three Phase Induction Motors: Concept of rotating magnetic field; Principle of operation	1
5.4	Types and constructional features; Slip and its significance	1
5.5	Applications of squirrel cage and slip ring motors; Necessity of a starter, star-delta starter.	1

<b>CO Assessment Questions</b>	
CO1	Given two resistances, draw a circuit with both of them so as to draw minimum current. (Understand)
CO1	What is the shape of the electrical voltage waveform coming to your house? Draw the waveform with neat label. (Remember)
CO1	Solve problems applying Ohms law and Kirchoff's Laws (Understand)
CO2	Define and explain the terms MMF, reluctance and permeability with the help of a neat sketch. (Remember)
CO2	Describe the concept of magnetic reluctance and its relationship to magnetic circuits. How does it affect the flow of magnetic flux? Provide an example that illustrates the calculation of reluctance in a simple series magnetic circuit. Present your reasoning in a clear and organized manner. (Understand)
CO3	The voltage and current across a circuit is out of phase by 30°. The voltage is having a frequency of 50Hz. Plot the waveforms and compute the real and reactive power. (understand)

CO3	Explain with the aid of a neat sketch, how the average and rms values of an alternating current are obtained. (Remember)
CO4	Three inductive coils, each with a resistance of $15\Omega$ and an inductance of $0.03\text{H}$ are connected in (i) star and (ii) delta, to 3-phase, 400V, 50Hz supply. Calculate for each of the above case (i) phase current and line current and (ii) total power absorbed. (Apply)
CO4	Submit a report by identifying three cases where star and delta connected three phase AC systems are used (Understand)
CO5	Identify the motors used in all the machines / lathe in the Machine shop. (Understand)

<b>24EST119</b>	<b>Basic Mechanical Engineering</b>	<b>L</b>	<b>T</b>	<b>P</b>	<b>J</b>	<b>S</b>	<b>C</b>	<b>Year of Introduction</b>
		<b>2</b>	<b>0</b>	<b>0</b>	<b>0</b>	<b>2</b>	<b>2</b>	<b>2024</b>

**Preamble:**

Enable the students to build a foundation in fundamentals of Mechanical Engineering, to correlate theoretical concepts with their industrial/engineering applications. The course imparts knowledge on various topics like thermodynamics, heat transfer, thermal and hydraulic machines. It helps the learners to prepare them for advanced concepts in Mechanical Engineering and to do interdisciplinary research.

**Prerequisite:** Nil

**Course Outcomes:** After the completion of the course the student will be able to

<b>CO 1</b>	Explain the significance and applications of thermodynamics and heat transfer (Understand, Apply)
<b>CO 2</b>	Illustrate the working and features of thermal power generation systems (Understand)
<b>CO 3</b>	Describe and compare the working of hydraulic machines (Understand)
<b>CO 4</b>	Explain the basic principles of Refrigeration and Air Conditioning systems (Understand)
<b>CO 5</b>	Discuss the basic manufacturing, metal joining and machining processes (Understand, Apply)

**CO - PO MAPPING**

CO	PO1	PO2	PO3	PO4	PO5	PO6	PO7	PO8	PO9	PO10	PO11	PO12
<b>CO 1</b>	✓	✓								✓		
<b>CO 2</b>	✓	✓										
<b>CO 3</b>	✓	✓							✓	✓		
<b>CO 4</b>	✓	✓										
<b>CO 5</b>	✓	✓							✓	✓		

**Assessment Pattern**

<b>Bloom's Category</b>	<b>Continuous Assessment Tools</b>			<b>End Semester Examination</b>
	<b>Test1</b>	<b>Test 2</b>	<b>Other tools</b>	
Remember	✓	✓	✓	✓
Understand	✓	✓	✓	✓
Apply	✓	✓	✓	✓
Analyse			✓	
Evaluate				
Create				

**Mark Distribution of CIA**

<b>Course Structure [L-T-P-J]</b>	<b>Attendance</b>	<b>Theory [L- T]</b>			<b>Total Marks</b>
		<b>Assignment</b>	<b>Test-1</b>	<b>Test-2</b>	
<b>2-0-0-0</b>	5	35	30	30	<b>100</b>

<b>Total Mark distribution</b>			
<b>Total Marks</b>	<b>CIA (Marks)</b>	<b>ESE (Marks)</b>	<b>ESE Duration</b>
100	100	0	-0

<b>SYLLABUS</b>
<b>MODULE I: Thermodynamics and Heat Transfer</b>
Thermodynamics: Laws of thermodynamics, Significance and Applications of Heat Engine, Heat Pump and Refrigerator — Efficiency, Coefficient of Performance (COP) Heat Transfer: Modes of Heat Transfer, Statement and explanation of Fourier's law of heat conduction, Newton's law of cooling, Stefan Boltzmann's law, Significance and Applications of heat transfer.
<b>MODULE II: Thermal power generation Systems</b>
<b>Boilers:</b> Classification, FBC <b>Steam Turbines:</b> Classification, Working principle of Impulse and reaction turbines, <b>Gas turbines:</b> Classification, Working principle of Open and Closed cycle Gas turbine, <b>IC Engines:</b> Classification, Working principle of two stroke and four stroke (SI and CI) Engines
<b>MODULE III: Fluid Machines</b>
<b>Pumps:</b> Types, Operation of Reciprocating and Centrifugal pumps <b>Hydraulic Turbines:</b> Classification, Description about working with sketches of: Pelton turbine, Francis turbine and Kaplan turbine. Overall efficiency, Problems on calculation of input and output power of pumps and turbines (No velocity triangles)
<b>MODULE IV: Refrigeration and Air Conditioning</b>
Refrigerant, Vapor compression refrigeration system- Principle, Domestic Refrigerator, Window and split air conditioners- Description about working with sketches.
<b>MODULE V: Manufacturing Process</b>
Basic description of the manufacturing processes ( <i>Basic Concepts only and examples of products</i> ) – Die Casting, Forging, Rolling, Extrusion. Basic description: Lathe Machine and Lathe operations, Drilling Basic description of Metal Joining Processes: Arc Welding, Soldering and Brazing and their applications,
<b>Text books</b>
1. Benjamin J., Basic Mechanical Engineering, Pentex Publishers Ltd., Kollam. 2. Balachandran P., Basic Mechanical Engineering, Owl publishers.
<b>Reference books</b>
1. Spalding and Cole, Engineering Thermodynamics, Hodder& Stoughton Educational. 2. Gill, Smith and Zuirys, Fundamentals of IC Engines, Oxford and IBH publishing Company Pvt. Ltd. New Delhi. 3. Crouse, Automobile Engineering, Tata Mc-Graw-Hill, New Delhi.



4. Roy and Choudhary, Elements of Mechanical Engineering, Media Promoters & Publishers Pvt. Ltd., Mumbai.
5. Bansal R.K., Fluid Mechanics and Machine, Laxmi Publications Pvt. Ltd. New Delhi.
6. Pravin Kumar, Basic Mechanical Engineering, Pearson.

<b>COURSE CONTENTS AND LECTURE SCHEDULE</b>		
No.		No. of Hours
<b>MODULE 1</b>		
1.1	Thermodynamics: Laws of thermodynamics, Significance and Applications	1
1.2	Heat engine, heat pump and refrigerator — Efficiency, Coefficient of Performance (COP)	1
1.3	Heat Transfer: Modes of Heat Transfer, Statement and explanation of Fourier's law of heat conduction, Newton's law of cooling, Stefan Boltzmann's law.	1
1.4	Significance and Applications of heat transfer	1
<b>MODULE II</b>		
2.1	<b>Thermal power generation Systems</b> <b>Boilers:</b> Classification, FBC	1
2.2	<b>Steam Turbines:</b> Classification, Working principle of Impulse and reaction turbines,	1
2.3	<b>Gas turbines:</b> Classification, Working principle of Open and Closed cycle Gas turbine	1
2.4	<b>IC Engines:</b> Classification, Working principle of four stroke (SI and CI) Engine	1
2.5	Working principle of two stroke (SI and CI) Engine	1
<b>MODULE III</b>		
3.1	<b>Fluid Machines</b> <b>Pumps:</b> Types, Operation of Reciprocating pumps	1
3.2	Operation of Centrifugal pumps	1
3.3	<b>Hydraulic Turbines:</b> Classification, Description about working with sketches of Pelton turbine	1
3.4	<b>Hydraulic Turbines:</b> Description about working with sketches of Francis turbine.	1
3.5	<b>Hydraulic Turbines:</b> Description about working with sketches of Kaplan turbine.	1
3.6	Overall efficiency, Problems on calculation of input and output power of pumps and turbines	1
<b>MODULE IV</b>		
4.1	<b>Refrigeration and Air Conditioning:</b> Refrigerant, Vapor	1

	compression refrigeration system - Principle	
4.2	Domestic Refrigerator - Description about the working with sketches	1
4.3	Window air conditioners - Description about the working with sketches	1
4.4	Split air conditioners - Description about the working with sketches	1
<b>MODULE V</b>		
5.1	Basic description of the manufacturing processes – Die Casting, Forging and their applications	1
5.2	Basic description of the manufacturing processes - Rolling, Extrusion, and their applications	1
5.3	Basic description: Lathe Machine and Lathe operations, Drilling	1
5.4	Basic description of Metal Joining Process: Arc Welding	1
5.5	Basic description of Metal Joining Processes: Soldering, Brazing, Applications	1

<b>CO Assessment Questions</b>		
1	<ol style="list-style-type: none"> <li>1. An office worker claims that a cup of cold coffee on his table warmed up to 80°C by picking up energy from the surrounding air, which is at 25°C. Is there any truth to his claim? Does this process violate any thermodynamic laws?</li> <li>2. Compare heat pump and refrigerator. Also obtain an expression for C.O.P.</li> <li>3. Prepare a report on the applications of heat transfer in industries.</li> <li>4. Consider two walls of a house that are identical except that one is made of 10-cm-thick wood, while the other is made of 25-cm-thick brick. Through which wall will the house lose more heat in winter?</li> </ol>	
2	<ol style="list-style-type: none"> <li>1. Compare impulse and reaction steam turbine and state applications</li> <li>2. Give the practical applications of Gas turbine</li> <li>3. Identify and explain with neat sketch, the working of the engine that gives one power stroke for two revolutions of crank shaft.</li> <li>4. Compare the working of 2 stroke and 4 stroke IC engines</li> </ol>	
3	<ol style="list-style-type: none"> <li>1. Explain the working of a pump with sketches used for low head and high discharge</li> <li>2. Prepare a report on the pumps with specifications used in industries</li> <li>3. Identify hydroelectric power plant that uses Pelton wheel turbine and illustrate the working of the turbine.</li> <li>4. A turbine is to operate under a head of 25 m at 200 rpm. The discharge is 9 m<sup>3</sup>/s. If the overall efficiency of the turbine is 90%. Determine the power developed by the turbine.</li> </ol>	
4	<ol style="list-style-type: none"> <li>1. Illustrate the principle of operation of household refrigerator.</li> <li>2. It is proposed to use water instead of refrigerant- 134a as the working fluid in air-conditioning applications where the minimum temperature never falls below the freezing point. Would you support this proposal?</li> </ol>	

	<p>Explain</p> <ol style="list-style-type: none"><li>3. With the help of suitable sketch explain the working of a split air conditioner</li><li>4. When selecting a refrigerant for a certain application, what qualities would you look for in the refrigerant?</li></ol>
5	<ol style="list-style-type: none"><li>1. Identify the manufacturing process that uses mould to produce desired parts? Explain the procedure.</li><li>2. Discuss the metal joining process to connect dissimilar metals.</li><li>3. Explain the method employed for making metal sheets in manufacturing process.</li><li>4. Submit a report by identifying three objects and list the different processes involved to obtain the finished product from raw material</li></ol>

24EST106	ENGINEERING MECHANICS						L	T	P	J	S	C	Year of Introduction
							2	1	0	0	3	3	2024
<b>Preamble:</b>													
The objective this course is to expose the students to the fundamental concepts of mechanics and enhance their problem-solving skills. It introduces students to the influence of applied force system and the geometrical properties of the rigid bodies. After this course students will be able to recognize similar problems in real-world situations and respond accordingly.													
<b>Prerequisite:</b> Nil													
<b>Course Outcomes:</b>													
CO	After the completion of the course the student will be able to												
<b>CO 1</b>	Recall principles and theorems related to rigid body mechanics. [Remember level]												
<b>CO 2</b>	Identify and describe the components of system of forces acting on a rigid body. [Understand level]												
<b>CO 3</b>	Apply the conditions of equilibrium to various practical problems involving different force systems. [Apply level]												
<b>CO 4</b>	Analyse linear, curvilinear and rotary motion of rigid bodies. [Apply level]												
<b>CO 5</b>	Determine the properties of distributed areas. [Apply level]												
<b>CO - PO MAPPING</b>													
CO	PO1	PO2	PO3	PO4	PO5	PO6	PO7	PO8	PO9	PO10	PO11	PO12	
<b>CO 1</b>	1	-	-	-	-	-	-	-	-	-	-	-	
<b>CO 2</b>	1	-	-	-	-	-	-	-	-	-	-	-	
<b>CO 3</b>	3	2	-	-	-	-	-	-	-	-	-	-	
<b>CO 4</b>	3	2	-	-	-	-	-	-	-	-	-	-	
<b>CO 5</b>	2	1	-	-	-	-	-	-	-	-	-	-	
<b>Assessment Pattern</b>													
Bloom's Category	Continuous Assessment Tools			End Semester Examination									
	Test1	Test 2	Other tools										
Remember	✓	✓	✓										
Understand	✓	✓	✓										
Apply	✓	✓	✓										
Analyse			✓										
Evaluate													
Create													
<b>Mark Distribution of CIA</b>													
Course Structure [L-T-P-J]	Attendance	Theory [L-T]			Total Marks								
		Assignment	Test-1	Test-2									
2-1-0-0	5	15	10	10	40								

<b>Total Mark distribution</b>			
<b>Total Marks</b>	<b>CIA (Marks)</b>	<b>ESE (Marks)</b>	<b>ESE Duration</b>
100	40	60	3 Hours
<b>End Semester Examination [ESE] Pattern</b>			
<b>Pattern</b>	<b>Part A</b>	<b>Part B</b>	<b>ESE Marks</b>
PATTERN 1	10 Questions, each question carries 2 marks  Marks: (2×10 =20 marks)	2 questions will be given from each module, out of which 1 question should be answered. Each question can have a maximum of 2 sub divisions. Each question carries 8 marks. Marks: (5×8 = 40 marks) Time: 3 hours	60
	Total Marks: 20	Total Marks: [5×8 = 40 marks]	
<b>SYLLABUS</b>			
<b>Module 1 (Resultant of Force Systems)</b>			
Introduction to Engineering Mechanics-statics-basic principles of statics-Parallelogram law, equilibrium law, principles of superposition and transmissibility, law of action and reaction(review) free body diagrams. Concurrent coplanar forces-composition and resolution of forces, resultant – methods of projections. Equilibrium – equations. Equilibrant. Non-Concurrent coplanar forces – Varignon’s Theorem of moments. Parallel coplanar forces – couple - resultant of parallel forces – centre of parallel forces. Resultant of non-Concurrent coplanar forces.			
<b>Module 2 (Equilibrium of Rigid Bodies)</b>			
Equilibrium of bodies subjected to general coplanar force system - equilibrium equations. Friction – sliding friction - Coulomb’s laws of friction – analysis of single bodies and connected bodies –wedges and ladder analysis.			
<b>Module 3 (Centroid and Moment of Inertia)</b>			
Concept of Centroid -Centroid of composite areas. Moment of inertia-parallel axis and perpendicular axis theorems. Polar moment of inertia, radius of gyration, mass moment of inertia-ring, cylinder and disc. Theorem of Pappus Guldinus (demonstration only).			
<b>Module 4 (Support Reactions of Beams, Forces in Space)</b>			
Beams - types of beams- Cantilever, Simple supported and Overhanging beams, Types of loading, Support reaction of beams subjected to concentrated loads, UDL, UVL and moments. Forces in space - vectorial representation of forces, moments and couples –resultant and equilibrium equations – concurrent forces in space (simple problems only)			
<b>Module 5 (Dynamics of Rigid Bodies)</b>			
Dynamics – review of Newton’s Laws –D’Alembert’s Principle. – motion on horizontal and inclined surfaces, motion of connected bodies.			

Impulse momentum equation and work energy equation (concepts only).  
 Curvilinear translation – Review of Kinematics- kinetics – equation of motion.  
 Rotation – kinematics of rotation- equation of motion for a rigid body rotating about a fixed axis – rotation under a constant moment.  
 Plane motion of rigid body – instantaneous centre of rotation (concept only).

**Text Books:**

1. Timoshenko and Young, Engineering Mechanics, McGraw Hill Publishers.
2. Shames, I. H., Engineering Mechanics - Statics and Dynamics, Prentice Hall of India.
2. R. C. Hibbeler and Ashok Gupta, Engineering Mechanics, Vol. I statics, Vol II Dynamics, Pearson Education.

**Reference Books:**

1. Merriam J. L and Kraige L. G., Engineering Mechanics - Vols. 1 and 2, John Wiley.
2. Tayal A K, Engineering Mechanics – Statics and Dynamics, Umesh Publications
3. Bhavikkatti, S.S., Engineering Mechanics, New Age International Publishers
4. F.P.Beer and E.R.Johnston (2011), Vector Mechanics for Engineers, Vol.I-Statics, Vol.II-Dynamics, 9<sup>th</sup> Ed, Tata McGraw Hill
5. Rajasekaran S and Sankarasubramanian G, Engineering Mechanics - Statics and Dynamics, Vikas Publishing House Pvt Ltd.

**COURSE CONTENTS AND LECTURE SCHEDULE**

No.		No. of Hour 36
<b>Module 1 (8 Hours)</b>		
1.1	Introduction to Mechanics – Mechanics of Rigid Bodies (EMS), Mechanics of deformable Bodies (MoS) and Mechanics of fluids (FM). Relevance of Engineering Mechanics, introduction to studies of bodies at rest (Statics) and studies of bodies in motion (Dynamics). Rigid bodies, Principle of transmissibility of forces, Principle of superposition, law of action and reaction.	1
1.2	Free body diagrams (FBDs) – concept and examples, Exercise problems on drawing FBDs.	1
1.3	Resolution of forces – rectangular components. Resultant of two forces - Parallelogram law.	1
1.4	System of coplanar forces – concurrent and non- concurrent forces.	1
1.5	Resultant force of a system of concurrent coplanar forces – method of projections.	1
1.6	Moment of a force, Varignon's Theorem of moments. Parallel coplanar forces – couple - resultant of parallel forces – centre of parallel forces	1
1.7	Resultant force of a system of non-concurrent coplanar forces	1
1.8	Resultant force of a system of non-concurrent coplanar forces	1

<b>Module II (7 Hours)</b>		
2.1	Equilibrium – equations for bodies subjected to coplanar concurrent and non- concurrent system of forces. Analysis of bodies subjected to system of coplanar concurrent forces.	1
2.2	Analysis of bodies subjected to system of coplanar non-concurrent forces.	1
2.3	Analysis of bodies subjected to system of coplanar non-concurrent forces.	1
2.4	Introduction to Friction – sliding friction - Coulomb's laws of friction – analysis of single bodies	1
2.5	Analysis of connected bodies	1
2.6	Problems on wedge friction	1
2.7	Problems on ladder friction	1
<b>Module III (8 Hours)</b>		
3.1	Centroid – Concept, Centroid of simple and regular geometrical shapes – Rectangle, right angled triangle, circle, semi-circle, sector of a circle/quadrant. Location of centroids using principle of moments. Centroid of simple figures using integration- Demonstration.	1
3.2	Centroid of composite areas- examples for illustration – problems for practice to be done by self.	1
3.3	Moment of Inertia-Concept, Moment of inertia of simple figures using integration.	1
3.4	Parallel axis theorem – Demonstration.	1
3.5	Moment of inertia - perpendicular axis theorem - example for illustration to be given as hand out and discussion on the solved example.	1
3.6	Polar moment of inertia, Radius of gyration. Mass moment of inertia of ring, cylinder and uniform disc. Theorem of Pappus Guldinus – Demonstration	1
3.7	Moment of Inertia-Concept, Moment of inertia of simple figures using integration.	1
3.8	Parallel axis theorem – Demonstration.	1
<b>Module IV (6 Hours)</b>		
4.1	Beams- Types, Support conditions, Loads on beams- Concentrated, UDL and UVL.	1
4.2	Support reactions of beam subject to concentrated loads	1
4.3	Support reactions of beam subject to UDL	1
4.4	Support reactions of beam subject to UVL, Support reactions of beams subject to concentrated moments – examples for illustration – problems for practice to be done by self.	1

4.5	Introduction to forces in space – vectorial representation of forces, moments and couples – simple problems to illustrate vector representations of forces, moments and couples.	1
4.6	Solution to practice problems - resultant and equilibrium equations for concurrent forces in space.	1
<b>Module V (7 Hours)</b>		
5.1	Introduction to dynamics – kinematics and kinetics. Kinetics- Newton’s Second Law, D’Alembert’s principle. – illustration of the concepts using one numerical exercise from motion on horizontal and inclined surfaces	1
5.2	Motion of connected bodies - example for illustration to be given as hand out and discussion on the solved example – problems for practice to be done by self.	1
5.3	Motion of connected bodies - example for illustration to be given as hand out and discussion on the solved example	1
5.4	Concepts of impulse momentum equation and work energy equation. Curvilinear translation – Review of Kinematics.	1
5.5	Curvilinear translation – Kinetics – equations.	1
5.6	Rotation – kinematics and kinetics of rotation- equation of motion for a rigid body rotating about a fixed axis, motion of cylinder/disc – rolling without slip.	1
5.7	Plane motion of rigid bodies – instantaneous centre of rotation (concept only).	1

<b>CO Assessment Questions</b>		
CO 1	1	State and explain principle of superposition of forces.
	2	Explain D’Alembert’s principle.
CO 2	1	A person is standing on the rung of a ladder placed on a smooth horizontal floor against a rough vertical wall. Identify all forces acting on the ladder and draw its free body diagram.
	2	A car is resting on an inclined plane as shown in figure. Identify all forces acting on the car and draw the free body diagram of the car.  
CO 3	1	A boy stands out at the end of the diving board, which is supported by two springs A and B, each having a stiffness of $k = 15 \text{ kN/m}$ . In the position shown the board is horizontal. If the boy has a weight of 400 N,

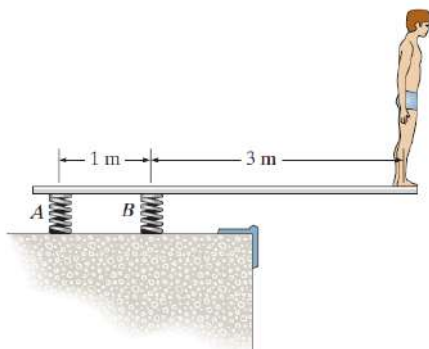
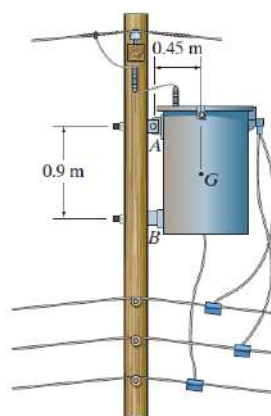
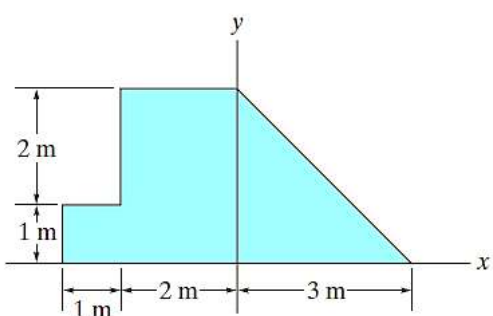

		<p>determine the angle of tilt which the board makes with the horizontal after he jumps off. Neglect the weight of the board and assume it is rigid.</p> 
	2	<p>The 1500-N electrical transformer with center of gravity at <math>G</math> is supported by a pin at <math>A</math> and a smooth pad at <math>B</math>. Determine the horizontal and vertical components of reaction at the pin <math>A</math> and the reaction of the pad <math>B</math> on the transformer.</p> 
CO 4	1	<p>An engine of weight 500 kN pull a train weighing 1500 kN up an incline of 1 in 100. The train starts from rest and moves with constant acceleration against a resistance of 5 N/kN. It attains a maximum speed of 36 kmph in 1 km distance. Determine the tension in the coupling between train and engine and the traction force developed by the engine.</p>
	2	<p>A right circular cylinder of mass <math>m</math> and radius <math>r</math> is suspended from a cord that is wound round its circumference. If the cylinder is allowed to fall freely, find the acceleration of its mass centre and tension in the cord.</p>
CO 5	1	<p>Locate the centroid of the plate shown in figure.</p> 

- 2 The cross section of a beam is shown in figure. Determine the moments of inertia of the section about its horizontal and vertical axes passing through the centroid.

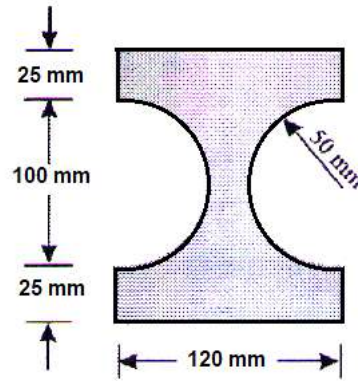

<b>23ECP112</b>	<b>ELECTRONIC DESIGN AND SIMULATION</b>	<b>L</b>	<b>T</b>	<b>P</b>	<b>J</b>	<b>S</b>	<b>C</b>	<b>Year of Introduction</b>
		<b>1</b>	<b>0</b>	<b>2</b>	<b>0</b>	<b>3</b>	<b>2</b>	<b>2024</b>

**Preamble:** This course gives a basic introduction to electronic components, circuits and simulation platforms. It is essential for keeping the learners aligned in the electronic stream from the very beginning and will be helpful in understanding core subjects with a practical mind set and help to simulate their theoretical understandings. The course inculcates a skill of learning by doing.

**Prerequisite:** NIL

**Course Outcomes:** After the completion of the course the student will be able to

<b>CO 1</b>	Identify and test various electronic components.(Understand Level)
<b>CO 2</b>	Simulate simple circuits using LT Spice. (Understand Level)
<b>CO 3</b>	Design first order RC circuits. (Understand Level)
<b>CO 4</b>	Perform testing of simple electronic circuits.(Apply Level)

#### CO - PO MAPPING

CO	PO1	PO2	PO3	PO4	PO5	PO6	PO7	PO8	PO9	PO10	PO11	PO12
CO 1	✓											
CO 2	✓				✓							✓
CO 3	✓	✓										
CO 4	✓	✓			✓							✓

#### Assessment Pattern for Theory component

Bloom's Category	Continuous Assessment Tools			End Semester Examination
	Test1	Test 2	Other tools	
Remember	✓	✓	✓	
Understand	✓	✓	✓	
Apply	✓	✓	✓	

#### Assessment Pattern for Lab component

Bloom's Category	Continuous Assessment Tools	
	Class work	Test1
Remember	✓	✓
Understand	✓	✓
Apply	✓	✓

<b>Mark Distribution of CIA</b>							
<b>Course Structure [L-T-P-J]</b>	<b>Attendance</b>	<b>Theory [L- T]</b>			<b>Practical [P]</b>		<b>Total Marks</b>
		<b>Assignment</b>	<b>Test-1</b>	<b>Test-2</b>	<b>Class work</b>	<b>Lab Exam</b>	
<b>1-0-2-0</b>	5	10	20	-	25	40	<b>100</b>
<b>Total Marks distribution</b>							
<b>Total Marks</b>	<b>CIA (Marks)</b>	<b>ESE (Marks)</b>			<b>ESE Duration</b>		
100	100	-			-		
<b>SYLLABUS</b>							
<b>MODULE I : Electronic Components &amp; Measuring Instruments (3 hours)</b>							
Power Supply: AC, DC, Variable supply. Parameters of Voltage and Current: Peak, RMS, Average value. Measuring Instruments: Voltmeter, Ammeter, Multimeter. Block diagram of Function Generator, CRO and DSO. Electronic components: Resistor, Capacitor, LED, LDR, Relay.							
<b>MODULE II : Electronic Simulation (2 hours)</b>							
Simulation Environments: LT Spice, Proteus. Diode – Characteristics simulation, equivalent model. Design and Simulation of simple circuits using LED, Resistor and switch.							
<b>MODULE III : Electronic Circuits (4 hours)</b>							
Clipping and Clamping Circuits: Working and simulation. Basic DC power supply with waveforms, SMPS and its comparison with linear power supply.							
<b>MODULE IV : First order RC Circuits (3 hours)</b>							
RC Time Constant and its derivation. Working and Simulation: RC Integrator, Differentiator, High Pass filter, Low Pass filter and its frequency response.							
<b>MODULE V : Printed Circuit Boards (1 hour)</b>							
PCB Chemical etching and PCB milling. Soldering – De soldering. Project using simple components: Design, Simulation and Prototyping.							
<b>Text books</b>							
<ol style="list-style-type: none"> <li>1. N.N. Bhargava, D.C.Kulshreshtha, S. C. Gupta, Basic Electronics and Linear circuits, Mc Graw Hill Education, 2nd edition, 2017.</li> <li>2. Robert Boylestad and L Nashelsky, “Electronic Devices and Circuit Theory”, 11/e Pearson, 2015.</li> <li>3. Simon Monk , "Make Your Own PCBs with EAGLE: From Schematic Designs to Finished Boards (Electronics)".</li> </ol>							
<b>Reference books</b>							
<ol style="list-style-type: none"> <li>1. David A Bell, “Electronic Devices and Circuits”, Oxford University Press, 2008.</li> </ol>							

2. Neamen D., "Electronic Circuits, Analysis and Design", 3/e, TMH, 2007.
3. Introduction to Spice simulation  
<https://www.coursera.org/lecture/averagedswitchmodelingandsimulation/introduction-to-spice-simulations-D8mvu>
4. LT Spice tutorial by ANALOG DEVICES  
<https://www.analog.com/en/education/education-library/videos/video-series/ltspice-getting-started-tutorial.html>

<b>COURSE CONTENTS AND LECTURE SCHEDULE</b>		
No.		No. of Hours
<b>MODULE 1</b>		
1.1	Power Supply: AC, DC, Variable supply. Parameters of Voltage and Current: Peak, RMS, Average value.	1
1.2	Measuring Instruments: Voltmeter, Ammeter, Multimeter.	1
1.3	Function Generator, CRO and DSO - block diagrams.	1
<b>MODULE II</b>		
2.1	Simulation Environments Introduction: LT Spice, Proteus	1
2.2	Diode - Characteristics, equivalent model. Design of simple circuit using LED, Resistor, Switch.	1
<b>MODULE III</b>		
3.1	Clipping Circuits	1
3.2	Clamping Circuits	1
3.3	Basic DC power supply with waveforms	1
3.4	SMPS block diagram and working.	1
<b>MODULE IV</b>		
4.1	RC Time Constant and its derivation.	1
4.2	Differentiator and Integrator	1
4.3	First Order RC Low Pass filter and High Pass filter.	1
<b>MODULE V</b>		
5.1	Basic process of PCB prototyping: Chemical etching and Milling	1

### LESSON PLAN FOR LAB COMPONENT

No.	Topic	No. of Hours	Experiment
1	Component value identification and testing.	1	Expt.1: Resistor and Capacitor value identification and testing.
2	Familiarization of Multimeter.	1	Expt.2: Measure voltage, current and resistance using multimeter.
3	Familiarization of DSO.	1	Expt.3: Measure frequency, Time period, $V_{pp}$ , $V_{max}$ , $V_{DC}$ of a given signal.
4	Familiarize components: LED, LDR and Potentiometer.	1	Expt.4: Test the working of LED, LDR and potentiometer.
5	Familiarize component: Relay	1	Expt.5: Setup a switching application using electromechanical relay.
6	BJT and FET Testing	1	Expt.6: Test FET and BJT using multimeter.
7	LT Spice and Proteus Introduction	1	Expt.7: Familiarize LT spice and proteus simulation environments components, visualizations.
8	Simulate diode characteristics	1	Expt.8: Simulate diode forward and reverse characteristics.
9	Simulate a simple basic circuit	1	Expt.9: Simulate an LED - resistor circuit and measure the current flow.
10	Simulate Clipping circuit	1	Expt.10: Simulate positive and negative clipping circuits and verify the transfer characteristics.
11	Simulate Clamping circuit	1	Expt.11: Simulate positive and negative clamping circuits.
12	Simulate DC Power supply	1	Expt.12: Simulate DC power supply and check waveforms at various nodes.
13	First order RC Circuit	1	Expt.13: Simulate RC differentiator and integrator.
14	First order RC Circuit	1	Expt.14: Simulate first order LPF and plot the

			frequency response.
15	First order RC Circuit	1	Expt.15: Simulate first order HPF and plot the frequency response.
16	Soldering and De-soldering	1	Expt.16: Solder the given components in general purpose PCB and de-solder them.
17	Troubleshooting Circuits	1	Expt.17: Troubleshoot the given circuit and make it working.
18	PCB Chemical etching	1	Expt.18: Perform chemical etching of PCB using FeCl solution.
19	PCB Milling	1	Expt.19: Convert a PCB layout to CNC machine file for PCB milling.
20	Project Design phase	1	Expt.20: Identify a problem and design a circuit to solve it.
21	Project Simulation	1	Expt.21: Simulate and verify the output of the designed circuit.
22	Project PCB Design	1	Expt.22: Design a PCB for your circuit.
23	Project Assembling and Testing	1	Expt.23: Assemble the components and test the prototype.

<b>CO Assessment Questions</b>	
1	Select a resistor/capacitor and identify its value and test it using a multimeter.
2	Simulate any series or shunt clipper in LT spice and verify the output.
3	Design a low pass filter and simulate the same in LT spice and verify the frequency response.
4	Troubleshoot the given faulty circuit and make it a functional circuit.

24EST115	Introduction to Electrical and Electronics Engineering	L	T	P	J	S	C	Year of Introduction 2024
		2	0	0	0		2	

**Preamble:** To provide the students with a broad perspective of the field of Electrical and Electronics Engineering. The course is designed to empower the students in solving simple electrical circuits. The course facilitates the students to identify the elements in simple electrical installations.

**Prerequisite:** Nil

**Course Outcomes:** After the completion of the course the student will be able to

**CO 1** Apply electrical laws to compute different circuit parameters. (Apply)

**CO 2** Analyse simple A.C. electrical circuits (Analyse level)

**CO 3** Analyse the three-phase system. (Analyse level)

**CO 4** Identify the basic components for the electrical installation. (Understand)

**CO 5** Identify the components in regulated DC power supply. (Understand)

**CO - PO MAPPING**

CO	PO1	PO2	PO3	PO4	PO5	PO6	PO7	PO8	PO9	PO10	PO11	PO12
CO 1	3	3										
CO 2	3	3										
CO 3	3								1			
CO 4	3					1		1	1			
CO 5	3											

**Assessment Pattern**

Bloom's Category	Continuous Assessment Tools			End Semester Examination
	Test1	Test 2	Other tools	
Remember	✓	✓	✓	✓
Understand	✓	✓	✓	✓
Apply	✓	✓	✓	✓
Analyse			✓	
Evaluate				
Create				

**Mark Distribution of CIA**

Course Structure [L-T-P-J]	Attendance	Theory [L- T]			Total Marks
		Assignment	Test-1	Test-2	
2-0-0-0	5	35	30	30	100

**Total Mark distribution**

Total Marks	CIA (Marks)	ESE (Marks)	ESE Duration
100	100	--	--



## **SYLLABUS**

### **MODULE I: Elementary concepts of electric circuits**

Elementary concepts of DC electric circuits: Basic Terminology including voltage, current, power, resistance, emf; Resistances in series and parallel; Ohms Law and Kirchhoff's laws- Star-delta conversion (resistive networks only-derivation not required) – Problems

Elementary concepts of AC electric circuits: Generation of alternating voltages  
Representation of sinusoidal waveforms: frequency, period, Average, RMS values and form factor of waveforms - Numerical problems.

### **MODULE II: Analysis of Sinusoidal quantities**

Representation of sinusoidal quantities & Analysis

Phasor representation of sinusoidal quantities. Rectangular, Polar and complex forms. Analysis of simple AC circuits: Purely resistive, inductive & capacitive circuits. Analysis of RL, RC and RLC series circuits. Calculation of reactance, impedance, power factor, real, reactive and apparent power - Numerical problems.

### **MODULE III: Three phase AC systems**

Three phase AC systems: Generation of three phase voltages; Comparison between single phase and three phase systems, balanced star and delta connections, relation between line and phase voltages, line and phase currents - Numerical problems.

### **MODULE IV: Electrical Installations**

Electrical Installation in Buildings - Main and distribution boards - Diagram Electric meter-basics, Panel board, MCB, RCCB, MCCB - working, uses, fuses-basics and types. Electrical Hazards, need of earthing, Safety & Precaution: Types, Causes. Safety & Precautions

Electrical wiring design - Electrical wiring system in domestic and light commercial buildings - Conduits, types of wiring, UG cables-basics, Accessories (Switches and Outlets, switch boards), Basic household wiring components - Symbols used in electrical wiring drawing layouts. Electrical Load calculation for a small residential building- Numerical problems.

### **MODULE V: Electronic circuits**

Introduction to semiconductor devices: PN Junction diode: principle of operation, VI characteristics, principle of avalanche breakdown. Bipolar Junction Transistors: Principle of operation, input and output characteristics of common emitter configuration.

Basic electronic circuits: Rectifiers and power supplies: Block diagram description of a dc power supply, working of a full wave bridge rectifier, capacitor filter (no analysis), working of simple Zener voltage regulator. Stress and Strain measurement using transducers.

### **Text books**

1. Hughes, Electrical Technology, Pearson, 10th Edition, 2011.
2. Fitzgerald and Higginbotham, Basic Electrical Engineering, McGraw Hill Inc, 1981.
3. D.P. Kothari and I. J. Nagrath, Basic Electrical Engineering, 3rd Edition, TMH, 2009
4. Basic Electrical Engineering, D. C. Kulshreshtha, McGraw-Hill Education, Revised first edition, 2019
5. K.B. Raina, S. K. Bhattacharya, "Electrical Design Estimation and Costing",

New Age International Publishers, Reprint 2010, ISBN(10):81-224-0363-8; ISBN(13): 978-81- 224-0363-3.

6. Electrical and Electronic Technology, Edward Hughes, Pearson, 12th edition, 2016

**Reference books**

1. W. H. Hayt, Jr J. E. Kemmerly and S. M. Durbin, Engineering Circuit Analysis, 7th Edn TMH, 2010.
2. Electrical Engineering Fundamental, Vincent Del Toro, Prentice Hall, New Delhi.
3. Fundamentals of Electrical Engineering and Electronics, B.L. Theraja, S Chand and Company, Reprint Edition 2013.
4. Principles Electrical Engineering and Electronics, V.K Mehta, Rohit Mehta, S Chand and Company, 2nd edition, 2015.
5. M.S.Sukhija and T.K.Nagsarkar, Basic Electrical and Electronics Engineering, Oxford University Press, 2012.
6. Chinmoy Saha, Arindham Halder and Debarati Ganguly, Basic Electronics - Principles and Applications, Cambridge University Press, 2018.
7. S. B. Lal Seksena and Kaustuv Dasgupta, “Fundamentals of Electrical Engineering”, Cambridge University Press.
8. Anant Agarwal, Jeffrey Lang, Foundations of Analog and Digital Electronic Circuits, Morgan Kaufmann Publishers, 2005.

**COURSE CONTENTS AND LECTURE SCHEDULE**

No.		No. of Hours [23 Hrs]
<b>MODULE 1</b>		
1.1	Basic Terminology including voltage, current, power, resistance, emf; Resistances in series and parallel; Ohms Law and Kirchhoff's laws	1
1.2	Star-delta conversion (resistive networks only-derivation not required) – Problems	1
1.3	Elementary concepts of AC electric circuits: Generation of alternating voltages Representation of sinusoidal waveforms: Frequency, period,	1
1.4	Average, RMS values and form factor of waveforms-numerical problems	1
<b>MODULE II</b>		
2.1	Representation of sinusoidal quantities & Analysis Phasor representation of sinusoidal quantities. Rectangular, Polar and complex forms	1
2.2	Analysis of simple AC circuits: Purely resistive, inductive & capacitive circuits	1
2.3	Analysis of RL and RC Calculation of reactance, impedance, power factor, real, reactive and apparent power- numerical problems	1

2.4	RLC series circuits Calculation of reactance, impedance, power factor, real, reactive and apparent power- numerical problems	1
<b>MODULE III</b>		
3.1	Three phase AC systems: Generation of three phase voltages; Comparison between single phase and three phase systems, balanced star and delta connections	1
3.2	Balanced star Relation between line and phase voltages, line and phase currents – numerical problems	1
3.3	Balanced delta connections, Relation between line and phase voltages, line and phase currents – numerical problems	1
<b>MODULE IV</b>		
4.1	Electrical Installation in Buildings - Main and distribution boards – Diagram, Electric meter-basics	1
4.2	Panel board, MCB, RCCB, MCCB - working, uses, fuses-basics and types	1
4.3	Electrical Hazards, need of earthing, Safety & Precaution: Types, Causes. Safety & Precautions	1
4.4	Electrical wiring design - Electrical wiring system in domestic and light commercial buildings - Conduits, types of wiring, UG cables-basics, Accessories (Switches and Outlets, switch boards)	1
4.5	Basic household wiring components - Symbols used in electrical wiring drawing layouts	1
4.6	Electrical Load calculation for a small residential building (Numerical problems)	1
<b>MODULE V</b>		
5.1	Introduction to Semiconductor devices: PN Junction diode: Principle of operation, V-I characteristics, principle of avalanche breakdown	1
5.2	Bipolar Junction Transistors: Principle of operation	1
5.3	Input and output characteristics of common emitter configuration	1
5.4	Basic electronic circuits: Rectifiers and power supplies: Block diagram description of a dc power supply	1
5.5	Working of a full wave bridge rectifier, capacitor filter (no analysis)	1
5.6	Working of simple Zener voltage regulator. Stress and Strain measurement using transducers	1

**CO Assessment Questions**

CO1	Given two resistances, draw a circuit with both of them so as to draw minimum current. (Understand)
CO1	What is the shape of the electrical voltage waveform coming to your house? Draw the waveform with neat label. (Remember)
CO1	Solve problems applying Ohms law and Kirchhoff's Laws (Apply)
CO2	Simple AC circuits (Analyze)
CO3	Submit a report by identifying three cases where star and delta connected three phase AC systems are used (Understand)
CO4	Make a video presentation on accidents due to improper earthing in electrical installations. (Understand)
CO5	Why a transistor is called so? (Understand)
CO5	Why do you require a regulated power supply? (Understand)

24ESL106	Introduction to Programming Frameworks	L	T	P	J	S	C	Year of Introduction 2024
		0	0	2	0	2	1	

**Preamble:** This course enables the students to investigate the features of python as a tool and comprehend its applicability in diverse domains of Computer Science and Engineering. The topics covered in the course are: Setting up the python environment, Data structures with Library functions, Data plotting and visualization, Basic Data analysis functions, Database interface with structured and non-structured Databases, Dealing with text, image and audio data representations, Interface with OS and networking modules. It helps the learners to use the features of this language while developing python based real world applications and to implement research-based projects.

**Prerequisite:** Nil

**Course Outcomes:** After the completion of the course the student will be able to

<b>CO1</b>	Identify the necessary packages and set up a programming development environment. [Understand Level]
<b>CO2</b>	Describe the development of GUI using packages and modules to facilitate interactive programming [Understand Level]
<b>CO3</b>	Explain about appropriate packages and functions available in python to implement basic data structures and related operations. [ Understand Level]
<b>CO4</b>	Illustrate processing and analysis of data graphically and statistically with appropriate packages and functions [ Understand Level]
<b>CO5</b>	Implement front end and database interface with structured and non structured Database. [ Understand Level]
<b>CO6</b>	Discuss the processing of text, image and audio data representation using python. [ Understand Level]
<b>CO7</b>	Explain about OS and networking modules in python. [ Understand Level]

**CO - PO MAPPING**

CO	PO1	PO2	PO3	PO4	PO5	PO6	PO7	PO8	PO9	PO10	PO11	PO12
CO1	✓	✓			✓			✓				✓
CO2	✓	✓			✓			✓				✓
CO3	✓	✓			✓			✓				✓
CO4	✓	✓			✓			✓				✓
CO5	✓	✓			✓			✓				✓
CO6	✓	✓			✓			✓				✓
CO7	✓	✓			✓			✓				✓

Bloom's Category	Continuous Assessment Tools	
	Class work	Test1
Remember		✓
Understand	✓	✓

Apply	✓	✓
Analyse		
Evaluate		
Create		

**Mark Distribution of CIA**

<b>Course Structure [L-T-P-J]</b>	<b>Attendance</b>	<b>Class work</b>	<b>Lab Exam</b>	<b>Total Marks</b>
<b>0-0-2-0</b>	<b>5</b>	<b>35</b>	<b>10</b>	<b>50</b>

**Total Mark distribution**

<b>Total Marks</b>	<b>CIA (Marks)</b>	<b>ESE (Marks)</b>	<b>ESE Duration</b>
<b>50</b>	<b>50</b>	<b>-</b>	<b>-</b>

**SYLLABUS- DETAILS OF EXPERIMENTS**

Setting up the environment: IDE setup, Package installation, GUI Development: Python Tkinter familiarization with GUI components. Data structures with Library functions: NumPy, Special Library functions in Python. Data plotting and visualization: Familiarization of Python Matplotlib components. Basic Data analysis functions: Statistical analysis and introduction to data distributions. Data processing and graphical analysis: Pandas for storing, accessing and basic pre processing tasks. Database interface with structured and non-structured Databases: MySQL and MongoDB Database connectivity and data access/manipulation operations, dealing with text, image and audio data representations: Image processing using OpenCV and Python, NLTK, Speech Recognition and Audio Signal Processing in Python, Interface with OS and networking modules: Python Networking, Sending mails, Internet accessing and OS interface functions.

**Text books**

1. Python Crash Course: A Hands-On, Project-Based Introduction to Programming by Eric Matthes
2. Python Cookbook by David Beazley, Brian K. Jones
3. Learn Python the Hard Way: A Very Simple Introduction to the Terrifyingly Beautiful World of Computers and Code, Third Edition, Zed Shaw

**Reference books**

1. The Python Bible 7 in 1: Volumes One To Seven, Florian Dedov
2. Publishing Python Packages, Dane Hillard, Manning Publications
3. Intuitive Python: Productive Development for Projects that Last, David Muller, The Pragmatic Bookshelf

**LIST OF EXPERIMENTS**

<b>No.</b>	<b>Experiments</b>
<b>I</b>	<b>Setting up the environment</b>
	Install Anaconda, Jupyter Notebook, Spider and necessary packages like NumPy, Pandas, Matplotlib, Seaborn, scikit-learn, NLTK, etc
<b>II</b>	<b>GUI Development-Python Tkinter</b>
	Write Python GUI programs to <ol style="list-style-type: none"><li>1. Import Tkinter package and create a window. Set its title and add a label to the window. Also create two buttons welcome and exit inside the window.</li><li>2. Create a Combo box with three options and a Check button widget using the tkinter module.</li><li>3. Create three single line text-box to accept your name, branch and year from the user using the tkinter module.</li><li>4. Create (a) a Scrolled Text widget (b) Progress bar widget and (c) List box bar widget using tkinter module</li><li>5. Create a Text widget using the tkinter module. Insert a string at the beginning then insert a string into the current text. Delete the first and last character of the text.</li></ol>
<b>III</b>	<b>Data structures with Library functions</b>
	<ol style="list-style-type: none"><li>1. Create Numpy arrays for Integer, Float, String, Boolean, and Complex data types.</li><li>2. Perform Reshape, Join and Split operations in the arrays.</li><li>3. Perform Search and Sort operations in Numpy arrays</li><li>4. Use random module to generate random numbers, 1-D and 2-D random arrays, shuffle and make a choice of random element from them.</li><li>5. Generate the following distributions using random module and visualize them using seaborn module: Normal, Binomial, Poisson, Uniform, Logistic, Exponential, Chi-Square, etc.</li></ol>
<b>IV</b>	<b>Data plotting and visualization</b>
	<ol style="list-style-type: none"><li>1. Generate a simple graph using Matplotlib. Also add titles and labels to the graph.</li><li>2. Generate a bargraph using matplotlib which shows the comparison of girls and boys opting for higher studies abroad over the last five years.</li><li>3. Using matplotlib generate a histogram to classify the population according to their age into five different bins.</li><li>4. Generate a piechart with matplotlib which shows the household expenses for a month.</li></ol>

	5. Take any two plots from above exercises and plot it in a single figure using subplot function
V	<b>Data analysis functions</b>
	<ol style="list-style-type: none"> <li>1. Find the mean, median, mode and standard deviation from a dataset which consists of 10 numbers.</li> <li>2. From a given array that consists of the marks of 15 students in a class find 80 percentile.</li> <li>3. Create an array with 100 random numbers between 5 and 10.</li> <li>4. Using the numpy module create a normal data distribution of 10000 values with mean 10 and standard deviation 2.</li> </ol>
VI	<b>Data processing and graphical analysis</b>
	<ol style="list-style-type: none"> <li>1. Create a Pandas Series and Dataframes from Dictionary</li> <li>2. Use pandas to read a CSV file and store it in a DataFrame and display the information about the data with sample 5 top and bottom rows</li> <li>3. Remove Empty data items, make data formats uniform, and remove the duplicates in it.</li> <li>4. Find the co-relation among the features in Data and interpret it with proper messages</li> <li>5. Use Scatterplot and histogram to describe the DataFrame Graphically</li> </ol>
VII	<b>Database interface with structured and non-structured Databases</b>
	<b>MySQL</b>
	<ol style="list-style-type: none"> <li>1. Install MySQL driver in your system and create a connection to the database and create a new database.</li> <li>2. Create a table student with three fields name, roll number and branch and set roll number as the primary key.</li> <li>3. Insert five rows into the table and select all records from the table and display the result.</li> <li>4. Delete a record from the table with the given name.</li> <li>5. Modify the name for a particular roll number.</li> </ol>



	<b>MongoDB</b>
	<ol style="list-style-type: none"> <li>1. Install MongoDB driver in your system and create a database called 'firstDB'</li> <li>2. Create a collection called customers with three fields: name, age and salary.</li> <li>3. Select all documents in the collection using the find () method.</li> <li>4. Find rows with salary equal to Rs.50000.</li> <li>5. Delete the document with a given name</li> </ol>
	<b>Dealing with text, image and audio data representations</b>
	<b>Image</b>
	<ol style="list-style-type: none"> <li>1. Write a program to read and display an image, show its dimensions and resize the image to a new dimension.</li> <li>2. Write a Python program to split the images into three constituent channels and find the average of pixel values in each channel and combine these channels back to the original image.</li> <li>3. Write a program to detect the edges in an image.</li> </ol>
	<b>Text</b>
	<ol style="list-style-type: none"> <li>1. Count the word frequency and remove stop words using NLTK</li> <li>2. Tokenize a text using NLTK</li> <li>3. Get synonyms and antonyms from WordNet</li> <li>4. Perform NLTK word stemming</li> <li>5. Perform Lemmatizing words using WordNet</li> </ol>
	<b>Speech Recognition and Audio Signal Processing</b>
VIII	<ol style="list-style-type: none"> <li>1. Open an audio file and read its contents, then record it into an AudioData instance</li> <li>2. Recognizing Speech in the Audio</li> <li>3. Read a Segment of Audio from the above file</li> <li>4. Install a microphone and capture its input with python</li> </ol>
	<b>Interface with OS and networking modules</b>
IX	<ol style="list-style-type: none"> <li>1. Python program to create socket client and socket server.</li> <li>2. Write a simple python program where the client makes a data request to the server and the server responds with the required data to the client.</li> </ol>

<b>CO Assessment Questions</b>	
1	Create a conda development environment installed with necessary packages for the development of an application dealing with Student data.
2	Create a registration form for enrolling into a course using python tkinter. The form should contain fields for entering your name, email id, gender(button),country(drop down menu) and course(checkbox). If any field is left empty proper warning message should be displayed.
3	a) Write a NumPy program to compute the mean, standard deviation, and variance of a given array along the second axis. b) Write a NumPy program to compute the covariance matrix of two given arrays.
4	Given a CSV file emp.csv with following columns (empno, name, designation, salary)of n employees. Write commands to do the following using pandas library. a) Read and display the content of emp.csv file b) Display the top 10 rows c) Display the list of all employees in the order of name e) Display the maximum salary and average salary f) Plot the histogram of salary
5	Create a database called 'customer' that contains customer name, age, gender, and the amount of the last purchase. Write a query to find customers who are either male or younger than 25.
6	Open an audio file and read its contents, then record it into an Audio Data instance. Print the text document corresponding to a small section from the same file.
7	Write a simple python program where the client makes a data request to the server and the server responds with the required data to the client.

<b>24CST105</b>	<b>LOGIC SYSTEM DESIGN</b>	<b>L</b>	<b>T</b>	<b>P</b>	<b>J</b>	<b>S</b>	<b>C</b>	<b>Year of Introduction 2024</b>
		<b>2</b>	<b>0</b>	<b>0</b>	<b>0</b>	<b>2</b>	<b>2</b>	

**Preamble:** This course enables the students to get an insight into the design of digital systems foundation and a cohesive understanding of how a computer works. This course covers functional units of a computer and different number systems, their representations and conversion, Boolean functions, combinational and sequential circuits, shift registers and counters. This course helps the learners to prepare for advanced digital system studies and carrier opportunities.

**Prerequisite:** NIL

**Course Outcomes:** After the completion of the course the student will be able to

**CO 1** Describe functional units of a computer and different number systems, their representations and conversion (**Understand level**).

**CO 2** Demonstrate the simplification of Boolean Function and design of suitable combinational circuit using Logic Gates (**Apply level**).

**CO 3** Explain the design of basic combinational circuits (**Understand level**).

**CO 4** Describe the design of basic sequential circuits (**Understand level**).

**CO 5** Explain shift registers and counters (**Understand level**).

#### CO - PO MAPPING

CO	PO1	PO2	PO3	PO4	PO5	PO6	PO7	PO8	PO9	PO10	PO11	PO12
CO 1	✓	✓										✓
CO 2	✓	✓										✓
CO 3	✓	✓										✓
CO 4	✓	✓										✓
CO 5	✓	✓										✓

#### Assessment Pattern

Bloom's Category	Continuous Assessment Tools			End Semester Examination
	Test1	Test 2	Other tools	
Remember	✓	✓	✓	✓
Understand	✓	✓	✓	✓
Apply	✓	✓	✓	✓
Analyse			✓	
Evaluate				
Create				

<b>Mark Distribution of CIA</b>					
<b>Course Structure [L-T-P-J]</b>	<b>Attendance</b>	<b>Theory [L- T]</b>			<b>Total Marks</b>
		<b>Assignment</b>	<b>Test-1</b>	<b>Test-2</b>	
<b>2-0-0-0</b>	<b>5</b>	<b>35</b>	<b>30</b>	<b>30</b>	<b>100</b>

**Total Mark distribution**

<b>Total Marks</b>	<b>CIA (Marks)</b>	<b>ESE (Marks)</b>	<b>ESE Duration</b>
100	100	-	-

**SYLLABUS**

**MODULE I : Basic structure of computers and Number conversions (6 hrs)**

Basic Structure of Computers: Functional units of a Computer, Basic operational concepts, Von Neumann Architecture. Data Representation: Binary Numbers Fixed Point Representation, Floating Point Representations. Number base conversions-Decimal, Binary, Octal and Hexadecimal Numbers, Signed binary numbers, r's Complements and (r-1)'s complement, Excess-3 code, Gray code, ASCII code, EBCDIC.

**MODULE II : Boolean expressions and functions (6 hrs)**

Boolean Expressions, Boolean functions, Simplification of Boolean Functions using SOP and POS. Logic gates, universal logic gates, Minimization of Logic expressions using Karnaugh map and Tabulation method.

**MODULE III : Combinational Circuits (5 hrs)**

Combinational Circuits- Binary Adder, Subtractor, BCD Adder, Comparator, Decoders, Encoders, Multiplexers, Demultiplexers, Code Converters.

**MODULE IV : Sequential Circuits (5 hrs)**

Sequential Circuits- Flip-flops: RS, JK, D, T flip flops, Master-slave flip flops, Edge-triggered flip-flops. Design of counters.

**MODULE V : Registers and Counters (4 hrs)**

Registers and Counters - Shift registers, Universal Shift register, Binary and BCD up counters (Synchronous and Asynchronous), Ring counter, Johnson counter (timing diagram).

**Text books**

1. Anita Goel, Computer Fundamentals, Pearson, 2010.
2. M. Morris Mano, Digital Logic & Computer Design, 4/e, Pearson Education, 2013.
3. Thomas L Floyd, Digital Fundamentals, 10/e, Pearson Education, 2009.
4. M. Morris Mano, Computer System Architecture, 3/e, Pearson Education, 2007.

**Reference books**

1. Donald D Givone, Digital Principles and Design, Tata McGraw Hill, 2003.
2. "Computer Organisation & Architecture", Smruti Ranjan Sarangi, McGraw Hill, 2014.

**NPTEL/SWAYAM Courses**

1. Digital Systems Design, Prof. D. Roychoudhury, IIT Kharagpur.
2. Digital System Design, Prof. Neeraj Goel, IIT Ropar.

**COURSE CONTENTS AND LECTURE SCHEDULE**

No.		No. of Hours (26)
<b>MODULE 1</b>		
1.1	Basic Structure of Computers: Functional units of a Computer	1
1.2	Basic Structure of Computers: Basic operational concepts, Von Neumann Architecture	1
1.3	Number base conversions- Decimal, Binary, Octal and Hexadecimal Numbers	1
1.4	Data Representation: Fixed Point Representation, Floating Point Representations.	1
1.5	Signed binary numbers, r's Complements and (r-1)'s complement	1
1.6	Excess-3 code, Gray code, ASCII code, EBCDIC	1
<b>MODULE II</b>		
2.1	Boolean Expressions, Boolean functions.	1
2.4	Simplification of Boolean Functions using SOP	1
2.3	Simplification of Boolean Functions using POS	1
2.4	Logic gates, universal logic gates	1
2.5	Minimization of Logic expressions using Karnaugh map	1
2.6	Minimization of Logic expressions using Tabulation method	1
<b>MODULE III</b>		
3.1	Combinational Circuits- Binary Adder, Subtractor	1
3.2	BCD Adder, Comparator	1
3.3	Decoders, Encoders	1
3.4	Multiplexers, Demultiplexers	1
3.5	Code Converters	1

<b>MODULE IV</b>		
4.1	Sequential Circuits- Flip-flops: RS flip flops	1
4.2	Sequential Circuits- Flip-flops: JK flip flops	1
4.3	Sequential Circuits-D, T flip flops	1
4.4	Master-slave flip-flops, Edge-triggered flip-flops	1
4.5	Design of counters	1
<b>MODULE V</b>		
5.1	Shift registers, Universal Shift register	1
5.2	Binary and BCD up counters (Synchronous and Asynchronous)	1
5.3	Ring counter	1
5.4	Johnson counter (Timing diagram)	1

<b>CO Assessment Questions</b>	
1	<ol style="list-style-type: none"> <li>The 16-bit 2's complement representation of an integer is 1111 1111 1111 0101. Find its decimal, octal, hexadecimal representations.</li> <li>Let the representation of a number in base 3 be 210. What is the hexadecimal representation of the number?</li> <li>Consider the equation <math>(43)_x = (y3)_8</math> where x and y are unknown. Find x and y.</li> <li>Consider the equation <math>(123)_5 = (x8)_y</math> where x and y are unknown. Find the number of possible solutions.</li> </ol>
2	<ol style="list-style-type: none"> <li>Let <math>f(w,x,y,z) = \sum(0,4,5,7,8,9,13,15)</math>. Which of the following expressions are NOT equivalent to f ? <ol style="list-style-type: none"> <li><math>x'y'z' + w'xy' + wy'z + xz</math></li> <li><math>w'y'z' + wx'y' + xz</math></li> <li><math>w'y'z' + wx'y' + xyz + xy'z</math></li> <li><math>x'y'z' + wx'y' + w'y</math></li> </ol> </li> <li>What is the minimum number of gates required to implement the Boolean function <math>(AB+C)</math> if we have to use only 2-input NOR gates?</li> <li>Which one of the following expressions does NOT represent exclusive NOR of x and y? <ol style="list-style-type: none"> <li><math>xy + x'y'</math></li> <li><math>x \oplus y'</math></li> <li><math>x' \oplus y</math></li> <li><math>x' \oplus y'</math></li> </ol> </li> <li>What is the Boolean expression for the output f of the combinational logic circuit of NOR gates given below?</li> </ol>

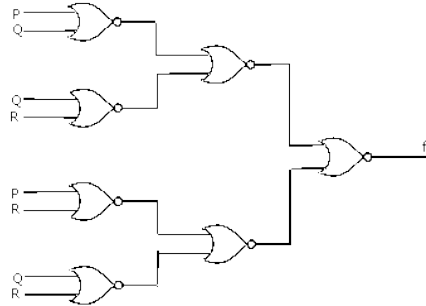

3

1. Design a Gray to binary code converter using a 4x1 MUX. Draw the circuit diagram and explain.
2. Suppose only one multiplexer and one inverter are allowed to be used to implement any Boolean function of  $n$  variables. What is the minimum size of the multiplexer needed?
3. Design a Full adder circuit using NAND gate only.
4. Design a magnitude comparator to check whether two numbers are equal or not.

4

1. Write the characteristics equation, excitation table of SR, T and D flip flops.
2. In a J-K flip-flop, we have  $J = Q'$  and  $K = 1$  (see figure). Assuming the flip-flop was initially cleared and then clocked for 6 pulses, find the sequence at the Q output.

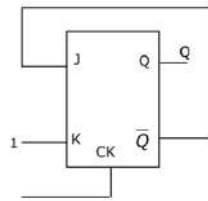

3. A three bit pseudo random number generator is shown below. Initially the value of output  $Y_2Y_1Y_0$  is set to 111. Find the value of  $Y_2$  after three clock pulses.

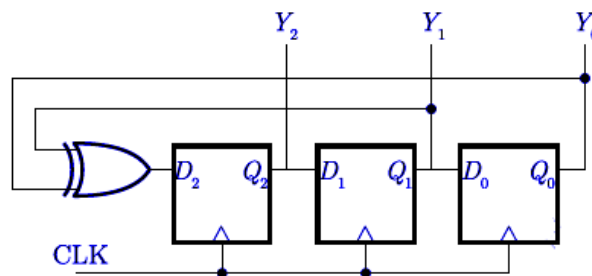

4. The outputs of the two flip flops  $Q_1$  and  $Q_2$  in the figure shown are initialized to 0, 0. Find the sequence generated at  $Q_1$  upon the application of clock signal.

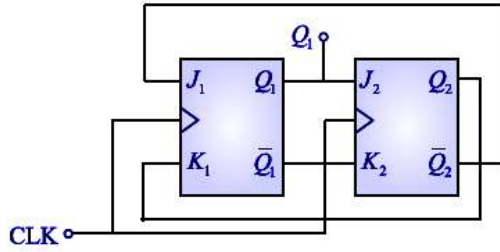

1. Consider a 4-bit Johnson counter with an initial value of 0000. The counting sequence of this counter is \_\_\_\_\_.
2. The circuit shown consists of J- K flip flops, each with an active low asynchronous reset ( $R_d$  input). Identify the counter corresponding to the given circuit.

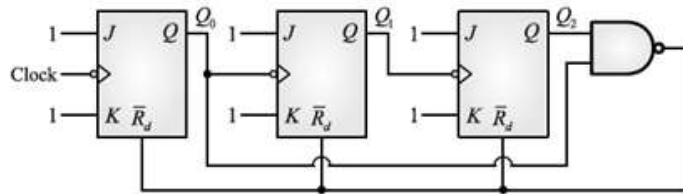

5

3. Consider a 3-bit counter, designed using T flip-flops, as shown below. Assuming the initial state of the counter given by PQR as 000, what are the next three states?

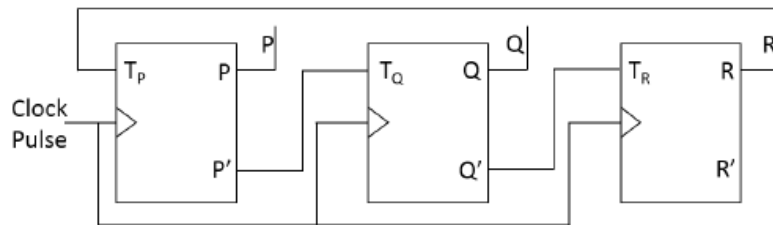



# SEMESTER II

24MAP200	Ordinary Differential Equations and Transforms	L	T	P	J	S	C	Year of Introduction
		3	1	2	0	5	5	2024

**Preamble:**

This course is to familiarize prospective engineers with some advanced concepts and methods in Mathematics which include ordinary differential equations, partial differential equations, and basic transforms such as Laplace and Fourier Transforms and Fourier series which are invaluable for any engineer's mathematical toolbox. The topics treated in this course have applications in all branches of engineering.

**Prerequisite:** Calculus of single and multivariable functions and partial differentiation.

**Course Outcomes:** After the completion of the course the student will be able to

<b>CO 1</b>	Solve homogeneous and non-homogeneous linear differential equations with constant coefficients (Apply level).
<b>CO 2</b>	Apply Laplace transforms to solve ordinary differential equations arising in engineering (Apply level).
<b>CO 3</b>	Develop the given functions as Fourier series expansions and apply them to solve problems arising in engineering (Apply level).
<b>CO 4</b>	Determine Fourier transforms of functions and learn their applications (Apply level).
<b>CO 5</b>	Use the concept of Z- transforms to solve practical problems (Apply level).

**CO - PO MAPPING**

CO	PO1	PO2	PO3	PO4	PO5	PO6	PO7	PO8	PO9	PO10	PO11	PO12
CO 1	✓	✓			✓			✓	✓			✓
CO 2	✓	✓			✓			✓	✓			✓
CO 3	✓	✓			✓			✓	✓			✓
CO 4	✓	✓			✓			✓	✓			✓
CO 5	✓	✓			✓			✓	✓			✓

**Assessment Pattern for Theory component**

Bloom's Category	Continuous Assessment Tools			End Semester Examination
	Test1	Test 2	Other tools	
Remember	✓	✓	✓	✓
Understand	✓	✓	✓	✓
Apply	✓	✓	✓	✓
Analyse				
Evaluate				
Create				

**Assessment Pattern for Lab component**

Bloom's Category	Continuous Assessment Tools	
	Classwork	Test1
Remember	✓	✓
Understand	✓	✓
Apply	✓	✓
Analyse		

Evaluate							
Create							
<b>Mark Distribution of CIA</b>							
Course Structure [L-T-P-J]	Attendance	Theory [L- T]			Practical [P]		Total Marks
		Assignment	Test-1	Test-2	Class work	Lab Exam	
<b>3-1-2-0</b>	5	10	12.5	12.5	10	10	<b>60</b>
<b>Total Marks distribution</b>							
<b>Total Marks</b>		<b>CIA (Marks)</b>		<b>ESE (Marks)</b>		<b>ESE Duration</b>	
100		60		40		2.5 hours	
<b>End Semester Examination [ESE]: Pattern</b>							
PATTERN	PART A		PART B			ESE Marks	
PATTERN 2			2 questions will be given from each module, out of which 1 question should be answered. Each question can have a maximum of 2 sub divisions.  Each question carries 8 marks.  Marks: (5x 8 = 40 marks)  Time: 2.5 hours			40	
	Total Marks: 0		Total Marks: [5x8 = 40 marks]				
<b>SYLLABUS</b>							
<b>MODULE I : (Ordinary differential equations)</b>							
Homogenous linear differential equation of second order, superposition principle, general solution, homogenous linear ODEs with constant coefficients-general solution. Solution of Euler-Cauchy equations (second order homogeneous only). Non-homogenous linear ODEs-general solution, solution by the method of undetermined coefficients (for the right-hand side of forms $x^n, e^{kx}, \sin ax, \cos ax, e^{ax} \sin ax, e^{ax} \cos ax$ and their linear combinations), method of variation of parameters. Solution of higher order equations-homogeneous linear ODE with constant coefficients.							
<b>MODULE II : (Laplace transforms)</b>							
Laplace Transform and its inverse, Existence theorem (without proof), linearity, Laplace transform of basic functions, first shifting theorem, Laplace transform of derivatives and integrals, solution of differential equations using Laplace transform, Unit step function, Second shifting theorem. Convolution theorem (without proof)							

and its application to finding inverse Laplace transform of products of functions.

### **MODULE III : (Fourier Series)**

Taylor series (without proof, assuming the possibility of power series expansion in appropriate domains), Binomial series and series representation of exponential, trigonometric, logarithmic functions (without proofs of convergence); Fourier series, Euler formulas, Convergence of Fourier series (without proof), half range sine and cosine series, Parseval's theorem (without proof).

### **MODULE IV : (Fourier Transforms)**

Fourier integral representation, Fourier sine and cosine integrals. Fourier sine and cosine transforms, inverse sine and cosine transform. Fourier transform and inverse Fourier transform, basic properties.

### **MODULE V : (Z -Transforms)**

Introduction to Z-transform, definition, some standard Z-transforms - and their inverses, linearity property, damping rule, some standard results, convolution, region of convergence of two-sided Z -transforms, evolution of inverse Z- transform using partial fraction.

#### **Text books**

1. H. Anton, I. Biven S.Davis, "Calculus", Wiley, 10<sup>th</sup> edition, 2015.
2. Erwin Kreyszig, "Advanced Engineering Mathematics", Wiley, 10<sup>th</sup> edition, 2015.
3. B.S. Grewal, Higher Engineering Mathematics, Khanna Publishers, 44th Edition, 2018

#### **Reference books**

1. J. Stewart, Essential Calculus, Cengage, 2<sup>nd</sup> edition, 2017
2. G.B. Thomas and R.L. Finney, Calculus and Analytic geometry, 9 th Edition, Pearson, Reprint, 2002.
3. Peter O Neil, Advanced Engineering Mathematics, 7th Edition, Thomson, 2007.
4. Louis C Barret, C Ray Wylie, "Advanced Engineering Mathematics", Tata McGraw Hill, 6<sup>th</sup> edition, 2003.
5. Veerarajan T, "Engineering Mathematics for first-year", Tata McGraw - Hill, 2008.
6. Srimanta Pal, Subodh C. Bhunia, "Engineering Mathematics", Oxford University Press, 2015.
7. Ronald N. Bracewell, "The Fourier Transform and its Applications", McGraw - Hill International Editions, 2000.
8. Prof. Haynes Miller, Prof. Arthur Mattuck, Differential Equations [MITOPENCOURSEWARE] <https://ocw.mit.edu/courses/18-03-differential-equations-spring-2010/download/>(Relevant sections)
9. Prof. Alan V. Oppenheim, Signals and Systems [MITOPENCOURSEWARE] <https://ocw.mit.edu/courses/res-6-007-signals-and-systems-spring-2011/pages/introduction/> (Relevant sections).

<b>COURSE CONTENTS AND LECTURE SCHEDULE</b>		
No.		No. of Hours
<b>MODULE 1</b>		
1.1	Homogenous linear equation of second order, Superposition principle, general solution	1
1.2	Homogenous linear ODEs of second order with constant coefficients.	1
1.3	Homogenous linear ODEs of second order with constant coefficients (continued).	1
1.4	Second order Euler-Cauchy equation	1
1.5	Non-homogenous linear differential equations of second order with constant coefficient-solution by undetermined coefficients.	1
1.6	Non-homogenous linear differential equations of second order with constant coefficient-solution by undetermined coefficients	1
1.7	Variation of parameters	1
1.8	Higher-order equations with constant coefficients	1
1.9	Higher-order equations with constant coefficients	1
<b>MODULE II</b>		
2.1	Laplace Transform, Inverse Transform, Linearity	1
2.2	First shifting theorem, transform of basic functions	1
2.3	Transform of derivatives and integrals	1
2.4	Solution of Differential equations, Initial value problems by Laplace transform method.	1
2.5	Solution of Differential equations, Initial value problems by Laplace transform method. (Continued)	1
2.6	Unit step function -Second shifting theorem	1
2.7	Unit step function -Second shifting theorem (Continued)	1
2.8	Convolution and related problems.	1
2.9	Convolution and related problems (Continued).	1
<b>MODULE III</b>		
3.1	Taylor series, Binomial series.	1
3.2	Taylor series, Binomial series (continued)	1
3.3	Series representation of exponential, trigonometric, and logarithmic functions	1
3.4	Fourier series, Euler formulas	1
3.5	Fourier series, Euler formulas (Continued)	1
3.6	Convergence of Fourier series (Dirichlet's conditions).	1
3.7	Half-range sine and cosine series	1

3.8	Half-range sine and cosine series (Continued)	1
3.9	Parseval's theorem.	1
<b>MODULE IV</b>		
4.1	Fourier integral representation	1
4.2	Fourier integral representation (Continued)	1
4.3	Fourier Cosine and Sine integrals	1
4.4	Fourier Cosine and Sine integrals (Continued)	1
4.5	Fourier Cosine and Sine transform	1
4.6	Fourier Cosine and Sine transform (Continued)	1
4.7	Fourier transforms and its inverse transforms, basic properties.	1
4.8	Fourier transforms and its inverse transforms, basic properties (Continued)	1
<b>MODULE V</b>		
5.1	Z-transform, some standard Z-transforms - and their inverses	1
5.2	Z-transform, some standard Z-transforms - and their inverses (Continued)	1
5.3	Linearity property, damping rule	1
5.4	Linearity property, damping rule (Continued)	1
5.5	Some standard results	1
5.6	Convolution	1
5.7	Region of convergence of two-sided Z -transforms	1
5.8	Region of convergence of two-sided Z -transforms (Continued)	1
5.9	Evolution of inverse Z- transform using partial fraction	1
5.10	Evolution of inverse Z- transform using partial fraction (Continued)	1

### **LESSON PLAN FOR LAB COMPONENT (Using Python Programming)**

<b>No.</b>	<b>Topic</b>	<b>No. of Hours</b>	<b>Experiment</b>
1.	Basic Mathematical Operations	4	Labels, Different Kinds of Numbers, working with fractions, complex numbers, calculating factors of an integer, generating multiplication tables, finding roots of a quadratic equation
2.	Visualizing Data with Graphs	4	Understanding the cartesian coordinate planes, working with lists and tuples, creating graphs with Matplotlib, Pyplot, and adding titles and labels.

3.	Algebra, Differentiation, Integral evaluations	4	Symbols, symbolic operations, matrix operations, differentiation, and integration.
4.	Ordinary Differential Equations	4	Solutions of ordinary differential equations, solution curves.
5.	Fourier Series	2	Fourier series of functions, graphical representation of Fourier series.
6.	Integral Transforms	2	Laplace and Fourier transform of functions, Inverse transform.

<b>CO Assessment Questions</b>	
1	<ol style="list-style-type: none"> <li>Solve <math>y'' - y = 0</math> for the initial conditions <math>y(0) = 1, y'(0) = -1</math>. Then change the initial conditions to <math>y(0) = 1.001, y'(0) = -0.999</math> and explain why this small change of 0.001 causes a larger change later. Sketch the graph of the solution in both cases using any Mathematical software and comment.</li> <li>Find the current <math>I(t)</math> in an <math>RLC</math>-circuit with <math>R = 11\Omega</math> (ohms), <math>L = 0.1\text{H}</math> (henry), <math>C = 10^{-2}</math> F (farad), which is connected to a source of EMF <math>E(t) = 110\sin(60 \cdot 2\pi t) = 110\sin 377t</math> (hence 60 Hz = 60cycles/sec, the usual in the U.S. and Canada; in Europe it would be 220 V and 50 Hz ). Assume that current and capacitor charge are 0 when <math>t = 0</math>.</li> <li>Solve the differential equation of <math>y''' - 3y'' + 3y' - y = e^x - x - 1</math>.</li> <li><b>Team Work:</b> A 10-kg mass is attached to a spring having a spring constant of 140 N/m. The mass is started in motion from the equilibrium position with an initial velocity of 1 m/sec in the upward direction and with an applied external force given by <math>\sin t</math> (in newtons). The mass is in a viscous medium with a coefficient of resistance equal to 90 N-sec m. Formulate an initial value problem that models the given system; solve the model and interpret the results. Also include Python code for solving ODE. Prepare a short report on the problem highlighting the observations you made and interpretation of the results.</li> </ol>
2	<ol style="list-style-type: none"> <li>Using convolution, determine the response of the damped mass-spring system modeled by <math>y'' + 3y' + 2y = r(t)</math>, <math>r(t) = 1</math> if <math>1 &lt; t &lt; 2</math> and 0 otherwise, <math>y(0) = y'(0) = 0</math>.</li> <li>Solve differential equation <math>9y'' + 6y' + y = 0, y(0) = 3, y'(0) = 1</math> using Laplace transforms. Use any mathematical software find the solution and compare the solutions.</li> <li><b>Team Work:</b> Find at least two applications of Laplace transforms in the engineering domain. Prepare a short report and a presentation of the same.</li> </ol>
3	<ol style="list-style-type: none"> <li>Use Maclaurin series of <math>\ln(1+x), -1 &lt; x \leq 1</math> to find an approximate value of <math>\ln 2</math>.</li> </ol>

	<p>2. Find the Fourier series of the function <math>f(x) = x^2, -2 \leq x &lt; 2, f(x + 4) = f(x)</math>. Hence using Parseval's identity prove that <math>1 + \frac{1}{2^4} + \frac{1}{3^4} + \dots = \frac{\pi^4}{90}</math>.</p> <p>3. <b>Team Work:</b> Find the Fourier series of the function obtained by passing the voltage <math>v(t) = V_0 \cos 100\pi t</math> through a half-wave rectifier that clips the negative half-waves.</p> <p>(a) Write a program for obtaining partial sum of the Fourier series so obtained.</p> <p>(b) Choose the first 5 or more partial sums until they approximate the given function reasonably well. Compare and comment.</p>
4	<p>1. Find Fourier cosine transform and sine transform of any function. Write a short report on ways of obtaining these transforms, with illustrations by examples of your own.</p> <p>2. Find the Fourier integral representation of function defined by <math>f(x) = e^{-x}</math> for <math>x &gt; 0</math> and <math>f(x) = 0</math> for <math>x &lt; 0</math>.</p> <p>3. <b>Team Work:</b> What are the conditions for the existence of Fourier Transform of a function <math>f(x)</math> and write at least two applications of Fourier transform in engineering domain. Sketch the function and its transform using any mathematical software.</p>
5	<p>1. Find Z- transform of the function <math>\sin(3n + 5)</math>.</p> <p>2. Find the Z- transform and region of convergence of <math>u(n) = C_k, n \geq k</math>.</p> <p>3. <b>Team Work:</b> Create a group of at least 8 students and identify an application of Z-transform in real life. Solve the problem using any mathematical software and comment on the result. Prepare a short report.</p>



24CYP203	<b>ENGINEERING CHEMISTRY (Circuit Branches)</b>	<b>L</b>	<b>T</b>	<b>P</b>	<b>J</b>	<b>S</b>	<b>C</b>	<b>Year of Introduction</b>
		<b>2</b>	<b>1</b>	<b>2</b>	<b>0</b>	<b>4</b>	<b>4</b>	<b>2024</b>

**Preamble:** Enable the students to build a solid foundation in fundamentals of chemistry, to correlate theoretical concepts with their industrial/engineering applications and to get hands-on laboratory experience on the principles discussed in theory sessions. The course imparts knowledge on various important topics like atomic and molecular structure, electrochemistry, etc., as they apply to the field of engineering and to familiarize the students with different application-oriented topics like spectroscopy, molecular electronics, nanomaterials, etc. It helps the learners to prepare them for advanced concepts in chemistry and to do interdisciplinary research.

**Prerequisite:** Higher secondary level Chemistry

**Course Outcomes:** After the completion of the course the student will be able to

<b>CO1</b>	Illustrate molecular orbital energy level diagram of diatomic molecules [Understand level]
<b>CO2</b>	Identify the suitable spectroscopy technique for the characterization of engineering materials and interpret spectral data. [Apply level]
<b>CO3</b>	Design electrochemical cells, compare the working of different electrochemical energy storage devices and describe corrosion control methods [Understand level]
<b>CO4</b>	Use the basic concepts of conducting polymers to design polymer based electronic devices [Apply level]
<b>CO5</b>	Recognize proper synthetic methods and describe applications of nanomaterials in science and engineering [Apply level]
<b>CO6</b>	Interpret molecular/system properties, gain skills to synthesize materials and carryout quantitative chemical analysis [Apply level]

**CO - PO MAPPING**

CO	PO1	PO2	PO3	PO4	PO5	PO6	PO7	PO8	PO9	PO10	PO11	PO12
CO 1	✓											✓
CO 2	✓	✓			✓				✓	✓		✓
CO 3	✓	✓							✓	✓		✓
CO 4	✓	✓							✓	✓		✓
CO 5	✓	✓			✓		✓		✓	✓		✓
CO 6	✓	✓			✓			✓	✓	✓		✓

**Assessment Pattern for Theory component**

Bloom's Category	Continuous Assessment Tools			End Semester Examination
	Test1	Test 2	Other tools	
Remember	✓	✓	✓	✓
Understand	✓	✓	✓	✓
Apply	✓	✓	✓	✓
Analyse				
Evaluate				
Create				

<b>Assessment Pattern for Lab component</b>							
<b>Bloom's Category</b>		<b>Continuous Assessment Tools</b>					
		<b>Class work</b>			<b>Test1</b>		
Remember							
Understand			✓			✓	
Apply			✓			✓	
Analyse							
Evaluate							
Create							
<b>Mark Distribution of CIA</b>							
<b>Course Structure [L-T-P-J]</b>	<b>Attendance</b>	<b>Theory [L- T]</b>			<b>Practical [P]</b>		<b>Total Marks</b>
		<b>Assignment</b>	<b>Test-1</b>	<b>Test-2</b>	<b>Class work</b>	<b>Lab Exam</b>	
<b>2-1-2-0</b>	5	10	12.5	12.5	10	10	60
<b>Total Marks distribution</b>							
<b>Total Marks</b>		<b>CIA (Marks)</b>		<b>ESE (Marks)</b>		<b>ESE Duration</b>	
100		60		40		2.5 hours	
<b>End Semester Examination [ESE]: Pattern</b>							
<b>PATTERN</b>	<b>PART A</b>		<b>PART B</b>			<b>ESE Marks</b>	
PATTERN 2			2 questions will be given from each module, out of which 1 question should be answered. Each question can have a maximum of 2 sub divisions. Each question carries 8 marks. Marks: (5x 8 = 40 marks) Time: 2.5 hours			40	
	Total Marks: 0		Total Marks: [5x8 = 40 marks]				
<b>SYLLABUS</b>							
<b>MODULE I: ATOMIC AND MOLECULAR STRUCTURE</b>							
Atomic and molecular orbitals - Postulates of molecular orbital theory - Linear Combination of Atomic Orbitals (LCAO) - Molecular orbitals of diatomic molecules - Molecular orbital energy level diagrams of N <sub>2</sub> and O <sub>2</sub> - Metallic bonding - Limitations of Valence Bond Theory (VBT) - Introduction to Crystal Field Theory (CFT) – Band structure of solids and the role of doping on band structures.							
<b>MODULE II: SPECTROSCOPIC TECHNIQUES AND APPLICATIONS</b>							
Introduction to spectroscopy - Beer Lambert's law (Numericals)- UV-vis spectroscopy (introduction, various electronic transitions and applications)- Vibrational spectroscopy (introduction, Number of vibrational modes of CO <sub>2</sub> and							

H<sub>2</sub>O, applications) - Surface characterization techniques: introduction and applications of X-ray photoelectron spectroscopy (XPS) and Auger electron spectroscopy (AES) - Diffraction: introduction and applications of X-Ray Diffraction (XRD)

### **MODULE III: ELECTROCHEMISTRY AND CORROSION**

Introduction - Differences between electrolytic and electrochemical cells - Daniel cell - Redox reactions - Cell representation - Construction and working of Calomel electrode - Electrochemical series and its applications - Nernst Equation (Derivation not required) - Single electrode and cell (Numericals) - Applications - Primary cells and secondary cells with examples - Construction and working of Lithium-ion cell - Introduction to fuel cell - Mechanism of electrochemical corrosion - Galvanic series - Cathodic protection.

### **MODULE IV: MOLECULAR ELECTRONICS**

Charge transport carriers - soliton, polaron, bipolaron - Conducting polymers - intrinsically and extrinsically conducting polymers - Polyaniline, Polyacetylene, Poly (p-phenylene) and Polypyrrole - Preparation, properties and applications - OLED - Principle, construction and advantages - Photoresist for electronics - Introduction to molecular devices based on conducting polymers (Field-effect transistor, Biosensors)

### **MODULE V: NANOMATERIALS**

Nanomaterials - Definition - Unique characteristics - Top-down and bottom-up approach for synthesis (Brief explanation) - Chemical methods of preparation - Hydrolysis, Reduction, Chemical vapor deposition (CVD) - Characterization techniques - Principle and instrumentation (block diagram) of Scanning electron Microscope (SEM) and Transmission electron microscope (TEM) - Introduction and applications of Graphene, Carbon nanotube, Quantum dots, MXenes, Metal organic framework.

#### **Text books**

1. AICTE's Prescribed Textbook: Chemistry – I with Lab Manual, Khanna Book Publishing.
2. Engineering Chemistry, by Manisha Agrawal.
3. University chemistry, by B. H. Mahan.
4. Chemistry: Principles and Applications, by M. J. Sienko and R. A. Plane.
5. Fundamentals of Molecular Spectroscopy, by C. N. Banwell.
6. Engineering Chemistry (NPTEL Web-book), by B. L. Tembe, Kamaluddin and M. S. Krishnan.
7. Physical Chemistry, by P. W. Atkins.
8. A Textbook of Engineering Chemistry, Shashi Chawla
9. NANO: The Essentials: Understanding Nanoscience and Nanotechnology, by T. Pradeep

#### **Reference books**

1. Muhammed Arif, Annette Fernandez, Kavitha P. Nair, Engineering Chemistry, Owl Books, 2019.

2. Ahad J., Engineering Chemistry, Jai Publication, 2019.
3. Roy K. Varghese, Engineering Chemistry, Crownplus Publishers, 2019.
4. Soney C. George & Rino Laly Jose, Text Book of Engineering Chemistry, S. Chand & Company Pvt Ltd, 2019.
5. Jain and Jain, Engineering Chemistry, DhanpatRai Publishers, 17th Edition, 2018.
6. Wiley India, Engineering Chemistry, ISBN 9788126543205

### **COURSE CONTENTS AND LECTURE SCHEDULE**

No.		No. of Hours
<b>MODULE 1</b>		
1.1	Atomic and molecular orbitals - Postulates of molecular orbital theory	1
1.2	Linear Combination of Atomic Orbitals (LCAO)	1
1.3	Molecular orbitals of diatomic molecules- Molecular orbital energy level diagrams of N <sub>2</sub>	1
1.4	Molecular orbital energy level diagrams of O <sub>2</sub>	1
1.5	Metallic bonding - Limitations of Valence Bond Theory (VBT)	1
1.6	Introduction to Crystal Field Theory (CFT)	1
1.7	Band structure of solids	1
1.8	Role of doping on band structures	1
<b>MODULE II</b>		
2.1	Introduction to spectroscopy	1
2.2	Beer Lambert's law (Numericals), UV-vis spectroscopy - introduction	1
2.3	Various electronic transitions – applications	1
2.4	Vibrational spectroscopy - introduction,	1
2.5	Number of vibrational modes of CO <sub>2</sub> and H <sub>2</sub> O - applications	1
2.6	Surface characterization techniques: introduction and applications of X-ray photoelectron spectroscopy (XPS) and Auger electron spectroscopy (AES)	1
2.7	Diffraction: introduction and applications of X-Ray Diffraction (XRD)	1
<b>MODULE III</b>		
3.1	Introduction - Differences between electrolytic and electrochemical cells - Daniel cell - Redox reactions	1
3.2	Cell representation - Construction and working of Calomel electrode	1
3.3	Electrochemical series and its applications	1
3.4	Nernst Equation (derivation not required) - Single electrode and cell (Numericals) – Applications	1

3.5	Primary cells and secondary cells with examples - Construction and working of Lithium-ion cell	1
3.6	Introduction to fuel cell - Mechanism of electrochemical corrosion	1
3.7	Galvanic series - cathodic protection.	1
<b>MODULE IV</b>		
4.1	Charge transport carriers - soliton, polaron, bipolaron	1
4.2	Conducting polymers - intrinsically and extrinsically conducting polymers	1
4.3	Polyaniline, Polyacetylene, Poly (p-phenylene) and Polypyrrole – Preparation, properties and applications	1
4.4	OLED - Principle, construction and advantages	1
4.5	Photoresist for electronics	1
4.6	Introduction to molecular devices based on conducting polymers	1
4.7	Field-effect transistor, Biosensors	1
<b>MODULE V</b>		
5.1	Nanomaterials - Definition - Unique characteristics	1
5.2	Top-down and bottom-up approach for synthesis (brief explanation) - Chemical methods of preparation - Hydrolysis	1
5.3	Chemical methods of preparation - Reduction, Chemical vapor deposition (CVD)	1
5.4	Characterization techniques – Principle and instrumentation (block diagram) of Scanning electron Microscope (SEM)	1
5.5	Principle and instrumentation (block diagram) of Transmission electron microscope (TEM)	1
5.6	Introduction and applications of Graphene, Carbon nanotube	1
5.7	Introduction and applications of Quantum dots, MXenes, Metal organic framework	1

**LESSON PLAN FOR LAB COMPONENT  
(Any 7 experiments to be conducted)**

No.	Topic	No. of Hours	Experiment
1	Electrochemistry	10	Experiment 1: Estimation of iron from iron ore/alloy Experiment 2: Determination of cell constant and conductivity of solutions Experiment 3: Potentiometric redox titration Experiment 4: Calibration of pH meter and determination of pH of solutions Experiment 5: Determination of pKa of weak acid using pH meter

2	Spectroscopy	4	Experiment 6: Analysis of IR spectra (minimum 3 spectra) Experiment 7: Analysis of XPS, AES, XRD spectra (minimum 3 spectra)
3	Synthesis of polymer and nanomaterial	8	Experiment 8: Synthesis of urea-formaldehyde Experiment 9: Synthesis of polyaniline Experiment 10: Synthesis of silver nanoparticles using chemical reduction method Experiment 11: Biogenic Synthesis of Silver Nanoparticles using plant extract
4	Water Chemistry	6	Experiment 12: Estimation of hardness of water by EDTA method Experiment 13: Determination of chloride content of water. Experiment 14: Determination of total alkalinity of water sample
5	Others	8	Experiment 15: Estimation of copper in brass Experiment 16: Identification of components in a mixture using TLC Experiment 17: Chemical analysis of a salt. Experiment 18: Chemical oscillations- Iodine clock reaction.

<b>CO Assessment Questions</b>	
1	Illustrate why the molecular orbital energy level diagram for O <sub>2</sub> is different from N <sub>2</sub>
2	<p>a) Choose a molecule. Find its IR spectrum from the web using any one of the following sources (i) AIST: Spectral Database for Organic Compounds (SDBS), <a href="https://sdb.sdb.aist.go.jp/sdb/cgi-bin/cre_index.cgi">https://sdb.sdb.aist.go.jp/sdb/cgi-bin/cre_index.cgi</a> (ii) NIST chemistry webbook, <a href="https://webbook.nist.gov/chemistry/">https://webbook.nist.gov/chemistry/</a> (iii) Sigma Aldrich, <a href="https://www.sigmaaldrich.com/IN/en">https://www.sigmaaldrich.com/IN/en</a> (iv) KnowItAll, <a href="https://www.knowitallanyware.com/#search">https://www.knowitallanyware.com/#search</a>.</p> <p>Interpret the spectrum in your own words highlighting how you can elucidate the structure of the molecule of your choice from the spectrum.</p> <p>b) Compare XPS and AES techniques and identify when each testing method is used.</p>
3	<p>a) Write the cell reactions of the following cell. Cd/CdSO<sub>4</sub>(0.01)//CuSO<sub>4</sub>(0.5M)/Cu. Sketch the electrochemical cell.</p> <p>b) Prepare a presentation on the topic “Energy storage devices; past, present and future”</p> <p>c) Write a report on the topic “Corrosion Control in Industry”</p>

4	<p>a) Prepare a table comparing various charge transport carriers in polymers</p> <p>b) Prepare a power point presentation on conducting polymer-based biosensors</p>
5	<p>a) Compare top-down and bottom-up methods for nanomaterial synthesis.</p> <p>b) Write a report on the role of nanotechnology in your branch of engineering</p> <p>c) Group discussion on “can nanotechnology offer solutions to environmental issues”</p>
6	<p>a) Estimate the amount of iron from iron ore using volumetric and potentiometric titrations, compare the results and identify which technique is more accurate.</p> <p>b) Collect water from three different sources. Measure their conductivity and pH and interpret the results.</p>

24ESP204	PROBLEM SOLVING AND PROGRAMMING	L	T	P	J	S	C	Year of Introduction
		3	0	2	0	5	4	2024

**Preamble:** This course enables students to acquire problem solving and programming skills to solve computational problems. This course covers Basics of Computer Hardware and Software, C Programming basics, arrays, strings, structure, union, functions, pointers and files. This course helps the learners to think logically, computationally and creatively to solve real world problems.

**Prerequisite:** Nil

**Course Outcomes:** After the completion of the course the student will be able to

<b>CO 1</b>	Formulate simple algorithms/flowcharts for arithmetic and logical problems using appropriate tools.[Apply level]
<b>CO 2</b>	Implement conditional branching, iteration and recursion.[Understand level]
<b>CO 3</b>	Use arrays, pointers and structures to formulate algorithms and implement programs.[Understand level]
<b>CO 4</b>	Decompose a problem into functions and synthesize a complete program using divide and conquer approach.[Understand level]
<b>CO 5</b>	Develop readable C programs with files for reading input and storing output.[Understand level]
<b>CO 6</b>	Test and execute the programs by correcting syntax and logical errors.[Understand level]

**CO - PO MAPPING**

CO	PO1	PO2	PO3	PO4	PO5	PO6	PO7	PO8	PO9	PO10	PO11	PO12
CO 1	✓	✓			✓			✓				✓
CO 2	✓	✓						✓				✓
CO 3	✓	✓						✓				✓
CO 4	✓	✓						✓				✓
CO 5	✓	✓						✓				✓
CO 6	✓	✓						✓				✓

**Assessment Pattern for Theory component**

Bloom's Category	Continuous Assessment Tools			End Semester Examination
	Test1	Test 2	Other tools	
Remember	✓	✓	✓	✓
Understand	✓	✓	✓	✓
Apply	✓	✓	✓	✓
Analyse			✓	
Evaluate				
Create				



<b>Assessment Pattern for Lab component</b>		
<b>Bloom's Category</b>	<b>Continuous Assessment Tools</b>	
	<b>Class work</b>	<b>Test1</b>
Remember		
Understand	✓	✓
Apply	✓	✓
Analyse	✓	✓
Evaluate	✓	
Create	✓	

<b>Mark Distribution of CIA</b>							
<b>Course Structure [L-T-P-J]</b>	<b>Attendance</b>	<b>Theory [L- T]</b>			<b>Practical [P]</b>		<b>Total Marks</b>
		<b>Assignment</b>	<b>Test-1</b>	<b>Test-2</b>	<b>Class work</b>	<b>Lab Exam</b>	
<b>3-0-2-0</b>	5	15	12.5	12.5	10	10	<b>60</b>

<b>Total Marks distribution</b>			
<b>Total Marks</b>	<b>CIA (Marks)</b>	<b>ESE (Marks)</b>	<b>ESE Duration</b>
100	60	40	2.5 Hours

**End Semester Examination [ESE]: Pattern**

<b>PATTERN</b>	<b>PART A</b>	<b>PART B</b>	<b>ESE Marks</b>
PATTERN 2		2 questions will be given from each module, out of which 1 question should be answered. Each question can have a maximum of 2 sub divisions. Each question carries 8 marks. Marks: (5x 8 = 40 marks) Time: 2.5 hours	40
	Total Marks: 0	Total Marks: [5x8 = 40 marks]	

**SYLLABUS**

**MODULE I : Basics of Computer Hardware and Software (7 hours)**

Basics of Computer Architecture: Processor, Memory, Input& Output devices. Application Software & System software: Compilers, interpreters, High level and low level languages, Introduction to structured approach to programming, Flow chart, Algorithms, Pseudo code (bubble sort, linear search - algorithms and pseudocode).

**MODULE II : Program Basics (8 hours)**

Basic structure of C program: Character set, Tokens, Identifiers in C, Variables and Data Types, Constants, Console IO Operations, printf and scanf. Operators

and Expressions: Expressions and Arithmetic Operators, Relational and Logical Operators, Conditional operator, size of operator, Assignment operators and Bitwise Operators, Operators Precedence. Control Flow Statements: If Statement, Switch Statement, Unconditional Branching using goto statement, While Loop, Do While Loop, For Loop, Break and Continue statements.(Simple programs covering control flow).

### **MODULE III : Arrays and strings (7 hours)**

Arrays Declaration and Initialization, 1-Dimensional Array, 2-Dimensional Array. String processing: In built String handling functions (strlen, strcpy, strcat and strcmp, puts, gets). Linear search program, bubble sort program, simple programs covering arrays and strings.

### **MODULE IV : Working with functions (7 hours)**

Introduction to modular programming, writing functions, formal parameters, actual parameters, Pass by Value, Recursion, Arrays as Function Parameters structure, union, Storage Classes, Scope and life time of variables, simple programs using functions.

### **MODULE V : Pointers and Files (7 hours)**

Basics of Pointer: Declaring pointers, accessing data through pointers, NULL pointer, array access using pointers, pass by reference effect. File Operations: open, close, read, write, append. Sequential access and random access to files: In built file handling functions (rewind() ,fseek(), ftell(), feof(), fread(), fwrite()), simple programs covering pointers and files.

#### **Text books**

1. Schaum's Outline of Programming with C, Byron Gottfried, Jitender Chhabra Tata McGraw Hill, 2005.
2. Programming in ANSI C, E. Balagurusamy, Mcgraw Hill, 2019.
3. Programming in C, Asok N Kamthane, Pearson Education, 2015.
4. Computer Fundamentals, Anita Goel, Pearson Education.

#### **References**

1. Computer fundamentals and Programming in C, Anita Goel and Ajay Mittal, Pearson Education, 2016.
2. The C Programming Language, Brian W. Kernighan and Dennis M. Ritchie, Pearson Education, 2015
3. Computer Basics and Programming in C, Rajaraman V, PHI, 2007.
4. Let us C, Yashavant Kanetkar, BPB Publications, 2016.

#### **NPTEL/SWAYAM Courses**

1. Introduction To Programming In C, Prof. Satyadev Nandakumar IIT Kanpur.
2. Problem Solving Through Programming In C, Prof. Anupam Basu IIT Kharagpur.

<b>COURSE CONTENTS AND LECTURE SCHEDULE</b>		
No.		No. of Hours
<b>MODULE 1</b>		
1.1	Basics of Computer Architecture: Processor	1
1.2	Basics of Computer Architecture: Memory	1
1.3	Basics of Computer Architecture: Input& Output devices	1
1.4	Application Software & System software: Compilers, interpreters, High level and low level languages	1
1.5	Introduction to structured approach to programming, Flow chart	1
1.6	Algorithms, Pseudo code	1
1.7	Bubble sort, linear search - algorithms and pseudocode	1
<b>MODULE II</b>		
2.1	Basic structure of C program: Character set, Tokens, Identifiers in C	1
2.2	Basic structure of C program: Variables and Data Types , Constants, Console IO Operations, printf and scanf	1
2.3	Operators and Expressions: Expressions and Arithmetic Operators, Relational and Logical Operators.	1
2.4	Operators and Expressions: Conditional operator, size of operator, Assignment operators and Bitwise Operators. Operators Precedence	1
2.5	Control Flow Statements: If Statement, Unconditional Branching using goto statement.(Simple programs covering control flow)	1
2.6	Control Flow Statements: Switch Statement, Break statement.(Simple programs covering control flow)	1
2.7	Control Flow Statements: While Loop, Do While Loop (Simple programs covering control flow)	1
2.8	Control Flow Statements: For Loop, Continue statement.(Simple programs covering control flow)	1
<b>MODULE III</b>		
3.1	Arrays Declaration and Initialization, 1-Dimensional Array, Simple programs covering 1 – Dimensional Array	1
3.2	Arrays Declaration and Initialization, 2-Dimensional Array , Simple programs covering 2 – Dimensional Array	1
3.3	Arrays -2- Programs covering 1 and 2 – Dimensional Arrays	1
3.4	String processing: In built String handling functions(strlen, strcpy, strcat and strcmp, puts, gets)	1
3.5	Linear search program- Implementation	1

3.6	Bubble sort program- Implementation	1
3.7	Simple programs covering arrays and strings	1
<b>MODULE IV</b>		
4.1	Introduction to modular programming - writing functions	1
4.2	Writing functions with formal parameters and actual parameters	1
4.3	Writing functions with Pass by Value and Recursion	1
4.4	Writing functions with arrays as Function Parameters	1
4.5	Structure and union	1
4.6	Storage Classes, Scope and life time of variables	1
4.7	Simple programs using functions	1
<b>MODULE V</b>		
5.1	Basics of Pointers: declaring pointers	1
5.2	Pointers: accessing data through pointers, NULL pointer, simple programs	1
5.3	Pointers: Array access using pointers, pass by reference effect, simple programs	1
5.4	File Operations: open, close, read, write, append	1
5.5	Programs using file operations	1
5.6	Sequential access and random access to files: In built file handling functions (rewind() ,fseek(), ftell(), feof(), fread(), fwrite()),	1
5.7	Sequential access and random access to files: Simple programs	1

### **LESSON PLAN FOR LAB COMPONENT**

<b>No.</b>	<b>Topic</b>	<b>No. of Hours</b>	<b>Experiment</b>
1	Basics of Computer Architecture: Processor, Memory, Input& Output devices	1	Familiarization of Hardware Components of a Computer
2	Application Software & System software: Compilers, interpreters, High level and low level languages	1	Familiarization of Linux environment – How to do Programming in C with Linux
3	Introduction to structured approach to programming, Flow chart	2	Familiarization of Tools - Flowgorithm and Raptor. Develop flowcharts and algorithms for a set of given problems

4	Basic structure of C program: Character set, Tokens, Identifiers in C, Variables and Data Types , Constants, Console IO Operations, printf and scanf	1	Familiarization of console I/O and operators in C i) Display "Hello World" ii) Read two numbers, add them and display their sum iii) Read the radius of a circle, calculate its area and display it iv) Evaluate the arithmetic expression $((a - b / c * d + e) * (f + g))$ and display its solution. Read the values of the variables from the user through console.
5	Operators and Expressions: Expressions and Arithmetic Operators, Relational and Logical Operators, Conditional operator, sizeof operator, Assignment operators and Bitwise Operators. Operators Precedence	1	i) Read 3 integer values and find the largest among them. ii) Read a Natural Number and check whether the number is prime or not iii) Read a Natural Number and check whether the number is Armstrong or not
6	Control Flow Statements: If Statement, Switch Statement, Unconditional Branching using goto statement, While Loop, Do While Loop, For Loop, Break and Continue statements.	1	
7	Arrays Declaration and Initialization, 1-Dimensional Array, 2-Dimensional Array	1	i) Read n integers, store them in an array and find their sum and average ii) Read n integers, store them in an array and search for an element in the array using an algorithm for Linear Search iii) Read n integers, store them in an array and sort the elements in the array using Bubble Sort algorithm
	Linear search program, bubble sort program	1	
8	String processing: In built String handling functions(strlen, strcpy, strcat and strcmp, puts, gets)	2	i) Read a string (word), store it in an array and check whether it is a palindrome

			<p>word or not.</p> <p>ii) Read two strings (each one ending with a \$ symbol), store them in arrays and concatenate them without using library functions</p> <p>iii) Read a string (ending with a \$ symbol), store it in an array and count the number of vowels, consonants and spaces in it.</p>
9	Introduction to modular programming, writing functions, formal parameters, actual parameters	2	<p>i) Find the factorial of a given Natural Number n using recursive and non recursive functions</p>
	Pass by Value, Recursion, Arrays as Function Parameters	2	<p>ii) Read a string (word), store it in an array and obtain its reverse by using a user defined function.</p> <p>iii) Write a menu driven program for performing matrix addition, multiplication and finding the transpose. Use functions to</p> <p>(a) read a matrix,</p> <p>(b) find the sum of two matrices, (c) find the product of two matrices,</p> <p>(d) find the transpose of a matrix and</p> <p>(e) display a matrix.</p>
10	Structure, union, Storage Classes, Scope and life time of variables, simple programs using functions	2	<p>i) Read two input each representing the distances between two points in the Euclidean space, store these in structure variables and add the two distance values.</p> <p>ii) Using structure, read and print data of n employees (Name, Employee Id and Salary)</p> <p>iii) Declare a union containing</p>

			5 string variables (Name, House Name, City Name, State and Pin code) each with a length of C_SIZE (user defined constant). Then, read and display the address of a person using a variable of the union.
11	Basics of Pointers: declaring pointers, accessing data through pointers, NULL pointer, array access using pointers, pass by reference effect	3	<ul style="list-style-type: none"> <li>i) Do the following using pointers <ul style="list-style-type: none"> <li>(a) add two numbers</li> <li>(b) swap two numbers using a user defined function</li> </ul> </li> <li>ii) Input and Print the elements of an array using pointers</li> <li>iii) Compute sum of the elements stored in an array using pointers and user defined function.</li> </ul>
12	File Operations: open, close, read, write, append	2	<ul style="list-style-type: none"> <li>i) Create a file and perform the following <ul style="list-style-type: none"> <li>(a) Write data to the file</li> <li>(b) Read the data in a given file &amp; display the file content on console</li> <li>(c) append new data and display on console</li> </ul> </li> <li>ii) Open a text input file and count number of characters, words and lines in it; and store the results in an output file.</li> </ul>
13	Sequential access and random access to files: In built file handling functions (rewind(), fseek(), ftell(), feof(), fread(), fwrite())	2	

### CO Assessment Questions

1	<p>Write an algorithm and draw flowchart (using Flowgorithm/Raptor)</p> <ul style="list-style-type: none"> <li>a) To find the roots of a quadratic equation</li> <li>b) To check whether largest of 3 natural numbers is prime or not</li> <li>c) To sort a set of numbers</li> </ul>
2	<p>Develop a C program</p> <ul style="list-style-type: none"> <li>a) To process a set of n natural numbers and to find the largest even number and smallest odd number from the given set of numbers. The program should not use division and modulus operators.</li> </ul>

	<p>b) To find the value of a mathematical function <math>f</math> which is defined as follows. <math>f(n) = n! / (\text{sum of factors of } n)</math>, if <math>n</math> is not prime and <math>f(n) = n! / (\text{sum of digits of } n)</math>, if <math>n</math> is prime.</p> <p>c) To evaluate the series <math>x - x^2/2! + x^3/3! - \dots</math> <math>n</math> terms, for a given values of <math>x</math> and <math>n</math>.</p>
3	<p>Write a C program</p> <p>a) To sort a set of <math>n</math> integers and to find the number of unique numbers and the number of repeated numbers in the given set of numbers. Use a function which takes an integer array of <math>n</math> elements, sorts the array using the Bubble Sorting Technique and returns the number of unique numbers and the number of repeated numbers in the given array.</p> <p>b) To read and multiply two matrices using pointers</p> <p>c) To process the marks obtained by <math>n</math> students of a class and prepare their rank list based on the sum of the marks obtained. There are 3 subjects for which examinations are conducted and the third subject is an elective where a student is allowed to take any one of the two courses offered.</p>
4	<p>Write a menu driven program to</p> <p>a) Read a matrix, display a matrix, add two matrices, multiply two matrices, check symmetry and transpose a matrix.</p> <p>b) To read the details of a set of students, display the details of all students, sort the details based on roll number, search for a student using name</p>
5	<p>Write a C program to</p> <p>a) Process a text file and to print the Palindrome words into an output file.</p> <p>b) Store the details of books in a library using a file and perform updation, deletion and insertion of a book from on the file based on title</p>
6	<p>Test and execute the above programs using a C Compiler.</p>



24EST206	ENGINEERING GRAPHICS	L	T	P	J	S	C	Year of Introduction
		2	2	0	0	2	4	2024

**Preamble:** Practicing Engineers require conversion of ideas and design into new products or in interpreting information from existing drawings. The course in Engineering Graphics deals with orthographic / pictorial projections, dimensioning and specifications, sectional views, isometric projection, development of surfaces and use of CAD software in preparing drawings. It enables the students to acquire basic knowledge about Engineering drawing and prepare themselves for a career in Engineering.

**Prerequisite :** Nil

**Course Outcomes:** After the completion of the course the student will be able to

<b>CO1</b>	Generate orthographic projections of lines inclined to one or both reference planes, ensuring accurate representation of their true length and orientation.
<b>CO2</b>	Construct orthographic projections of solids with axes inclined to one or both reference planes, demonstrating an understanding of their spatial orientation and dimensions.
<b>CO3</b>	Create sectional views of various solids, including prisms, pyramids, cones, and cylinders when cut by different section planes.
<b>CO4</b>	Create developed surfaces of solids that have been cut by different section planes.
<b>CO5</b>	Prepare pictorial drawings using the principles of isometric projection to visualize objects in three dimensions and convert isometric views to orthographic views.
<b>CO6</b>	Prepare multi-view orthographic projections of 3D solids using CAD tools by visualizing them in different positions.

**CO - PO MAPPING**

CO	PO1	PO2	PO3	PO4	PO5	PO6	PO7	PO8	PO9	PO10	PO11	PO12
CO 1	3											
CO 2	3											
CO 3	3											
CO 4	3											
CO 5	3									3		2
CO 6	3				3					3		2

**Assessment Pattern for Theory component**

Bloom's Category	Continuous Assessment Tools			End Semester Examination
	Test1	Test 2	Other tools	
Remember	✓	✓	✓	✓
Understand	✓	✓	✓	✓
Apply	✓	✓	✓	✓
Analyse				
Evaluate				
Create				

<b>Assessment Pattern for Lab component</b>					
<b>Bloom's Category</b>		<b>Continuous Assessment Tools</b>			
		<b>Class work</b>		<b>Test1</b>	
Remember					
Understand		✓		✓	
Apply		✓		✓	
Analyse					
Evaluate					
Create					
<b>Mark Distribution of CIA</b>					
<b>Course Structure [L-T-P-J]</b>	<b>Attendance</b>	<b>Theory [L- T]</b>			<b>Total Marks</b>
		<b>Assignment</b>	<b>Test-1</b>	<b>Test-2</b>	
<b>2-2-0-0</b>	5	10	12.5	12.5	<b>40</b>
<b>Total Marks distribution</b>					
<b>Total Marks</b>	<b>CIA (Marks)</b>	<b>ESE (Marks)</b>		<b>ESE Duration</b>	
100	40	60		3 hrs	
<b>End Semester Examination [ESE]: Pattern</b>					
<b>PATTERN</b>	<b>PART A</b>	<b>PART B</b>			<b>ESE Marks</b>
PATTERN 3		2 questions will be given from each module, out of which 1 question should be answered.  Each question carries 12 marks.  Marks: (5x 12 = 60 marks)  Time: 3 hours			60
	Total Marks: 0	Total Marks: [5x12 = 60 marks]			
<b>SYLLABUS</b>					
<b>MODULE I: Introduction to Engineering Drawing &amp; Orthographic Projections</b>					
Principles of Engineering Graphics and their significance, usage of Drawing instruments, lettering, Dimensioning. Principles of Orthographic Projections- Conventions - Projections of Points and projection of lines parallel to/inclined to both reference planes. Traces of lines.					
<b>MODULE II: Projections of Regular Solids</b>					
Projection of solids-Prisms, pyramids, solids of revolution-cone, cylinder. Solids with axis parallel to/ inclined to both the reference Planes- Auxiliary Views.					
<b>MODULE III: Sections and Sectional Views of Right Angular Solids</b>					
Sections of Solids: Sections of Prisms, Pyramids, Cone, Cylinder with axis in					

vertical position and cut by different section planes. True shape of the sections. Also locating the section plane when the true shape of the section is given.

**MODULE IV: Development of Surfaces**

Development of Surfaces: Development of surfaces of the Prisms, Pyramids, Cone, Cylinder with axis in vertical position, development of surfaces of solids cut by different section planes. Shortest distance between two points on the surface.

**MODULE V: Isometric Projections & 2D Drafting using software**

Isometric Projection: Isometric View and Projections of Prisms, Pyramids, Cone, Cylinder, Frustum of Pyramid, Frustum of Cone, Sphere, Hemisphere and their combinations. Conversion of Isometric Views to Orthographic Views.

**AutoCAD (Internal Evaluation only)**

Demonstrating knowledge of a 2D drafting software - Toolbars (Standard, Object Properties, Draw, Modify and Dimension), Prepare orthographic views of 3 D objects from their isometric views.

**Text books**

1. P. I. Varghese, Engineering Graphics, Tata McGraw Hill Education
2. Prof. J Benjamin, Engineering Graphics, Pentex Publishers

**Reference books**

1. N. D. Bhatt, Engineering Drawing, Charotar Publishing House
2. <https://nptel.ac.in/courses/112/103/112103019> (MOOC Course)

**COURSE CONTENTS AND LECTURE SCHEDULE**

No.		No. of Hours[44]
<b>MODULE 1[10]</b>		
1.1	Principles of Engineering Graphics and their significance, usage of Drawing instruments, lettering, Dimensioning	1
1.2	Principles of Orthographic Projections-Conventions - Projections of Points	1
1.3	Projections of Points (Problems on projection of points)	1
1.4	Projection of lines parallel to/inclined to one reference plane.	1
1.5	Projection of lines inclined to both reference planes. Line rotation method	1
1.6	Problem on lines inclined to both planes	1
1.7	Problem on lines inclined to both planes when apparent lengths are given.	1
1.8	Traces of lines using line rotation.	1
1.9	Problems on Lines using plane rotation method	1
1.10	Problems on Lines when traces are given.	1

<b>MODULE II [12]</b>		
2.1	Projection of solids- Prisms, pyramids - simple position	1
2.2	Projection of solids- Cylinder, cone - simple position	1
2.3	Projection of solids-Prisms and cylinder inclined to one plane.	1
2.4	Projection of solids-pyramid and cones inclined to one plane.	1
2.5	Projection of solids-Prisms inclined to both the reference Planes	1
2.6	Projection of solids-Pyramids inclined to both the reference Planes	1
2.7	Projection of solids-Cone inclined to both the reference Planes	1
2.8	Projection of solids-Cylinders inclined to both the reference Planes	1
2.9	Problems on projection of solids inclined to both planes.	2
2.10	Solids resting on VP	2
<b>MODULE III [7]</b>		
3.1	Introduction to section- Types of section planes -Sectional orthographic view of Prism when section plane perpendicular to VP inclined to HP	1
3.2	Sectional orthographic view of Pyramid when section plane perpendicular to VP inclined to HP	1
3.3	Sectional orthographic view of prism and Cylinder when section plane perpendicular to VP inclined to HP	1
3.4	Sectional orthographic view of Cone when section plane perpendicular to VP inclined to HP	1
3.5	Sectional orthographic view of above solids when section plane perpendicular to HP inclined to VP	1
3.6	Problems on Sectional orthographic view of above solids when true shape of the section is given	2
<b>MODULE IV [7]</b>		
4.1	Development of surfaces of Right Regular Solids – Prism.	1
4.2	Development of surfaces of Pyramid.	1
4.3	Problems on development of Prism and Pyramid for sectional solids.	2
4.4	Development of surfaces of Right Regular Solid- Cone and Cylinder.	1
4.5	Problems on development showing shortest path.	2
<b>MODULE V [8]</b>		
5.1	Principles of Isometric Projection-Isometric Scale-Isometric view	1
5.2	Isometric view of simple solids (Pyramids and Prisms)	1
5.3	Isometric view of simple solids (Cylinder and Cone)	1

5.4	Isometric projection of above solids	1
5.5	Isometric projection of Compound solids.	2
5.6	Conversion of Isometric Views to Orthographic Views.	2
<b>Total Hours</b>		<b>44</b>

### LESSON PLAN FOR LAB COMPONENT

No.	Topic	No. of Hours	Experiment
1	Familiarization with AutoCAD commands and tools	2	Auto CAD drawing of Simple geometries
2	Dimensioning, conversion of isometric views in to orthographic views using AutoCAD	2	Conversion of simple components to orthographic views

<b>CO Assessment Questions</b>	
CO1	<ol style="list-style-type: none"> <li>1. A line AB inclined at <math>40^\circ</math> to HP has its ends 50mm and 20mm above the HP. The length of its elevation is 65mm and its VT is 10 mm above the VP. Determine the true length of AB, its inclination with HP and its HT. How far the point HT from the X-Y line.</li> <li>2. The end P of a line PQ is 30mm in front of VP and 40 mm above HP, while Q is behind VP and 10 mm above HP. The distance between projectors is 70mm. if the line joining the top views makes an angle of <math>45^\circ</math> with the XY line. Draw the projections and find (i) True length (ii) True inclinations (iii) locate the traces.</li> <li>3. Two LED lights are to be fixed on a badminton court. The lights are 1m and 6 m away from a fixed vertical wall and 6m and 5m above the floor respectively. The distance between the lights measured parallel to the wall is 7m. Draw the projections assuming the wall as VP and the floor as HP. Also, find the actual length of the wire required to connect the two LED lights. Use a suitable scale.</li> </ol>
CO2	<ol style="list-style-type: none"> <li>1. A square prism of base side 30mm and length 50mm has a base edge on HP, axis inclined at <math>35^\circ</math> to HP. The base edge on which it rests is inclined <math>45^\circ</math> to VP. Draw the projections of solid.</li> <li>2. A hexagonal pyramid having a base with a 30mm side and a 50mm long axis rests on one of its base corners on the ground with axis inclined at <math>45^\circ</math> to the HP. Draw the projections when the vertical plane containing the axis and the corner makes <math>30^\circ</math> with the VP.</li> <li>3. The trophy to be given to the winners of the football tournament has a frustum of a hexagonal pyramid with the base hexagon of 30mm side,</li> </ol>

	<p>top hexagon of 20mm side and height 80mm. the frustum is placed on top of a square prism of 100mm side and height 20mm. a sphere of radius 28mm is placed centrally on top of the frustum. Draw the plan and elevation of the trophy.</p>
CO3	<ol style="list-style-type: none"> <li>1. A square prism having a base of 40mm side and 60mm long axis rests on its base on the HP such that one of the vertical faces makes an angle of <math>30^\circ</math> with the VP. A section plane perpendicular to the VP, inclined at <math>45^\circ</math> to the HP and passing through the axis at a point 20mm from its top end, cuts the prism. Draw the front view, sectional top view and true shape of the section.</li> <li>2. A cube with 45mm long edges rests on HP with vertical faces equally inclined to the VP. It is cut by a section plane perpendicular to the VP so that the true shape of the section is a regular hexagon. Draw the sectional top view and the true shape of the section. Determine the inclination of the section plane with the HP.</li> </ol>
CO4	<ol style="list-style-type: none"> <li>1. A cone with a 50 mm base diameter and 70 mm long axis rests on its base on the HP. Draw the development of its lateral surface when it is cut by an auxiliary inclined plane bisecting the axis and inclined at <math>45^\circ</math> to the HP.</li> <li>2. A hexagonal prism having base with a 30mm side and a 70mm axis is resting on its base on the ground with a side of base inclined at <math>45^\circ</math> to the VP. It is cut by an auxiliary inclined plane making an angle of <math>45^\circ</math> with the HP and passing through a point 15 mm below the top end of the axis. Obtain the development of the lateral surface of the truncated prism.</li> <li>3. A sugar jar is in the form of a right circular cone of base diameter 60 mm and height 90 mm and it rests on HP. An ant starts moving from extreme left end of its base, returns to its starting point, after moving around it. Find geometrically the length of the shortest path the ant can take. Show this in both front and top views.</li> </ol>
CO5	<ol style="list-style-type: none"> <li>1. A hemisphere of diameter 80mm is resting on the ground with its flat surface facing upwards. A square pyramid having side of base 40mm and axis 60mm is resting on the base centrally on the top of the hemisphere. Draw the isometric view of the combination of solids.</li> <li>2. A waste basket is of the shape of a frustum of a hexagonal pyramid with base side 30 cm, top side 50 cm and height 100 cm. Draw the isometric projection of the basket which is standing vertically with smaller hexagonal base on the ground.</li> <li>3. Using any free software (2D drafting software), prepare the three orthographic views of the machine component shown in figure, following the ISO standards.</li> </ol>

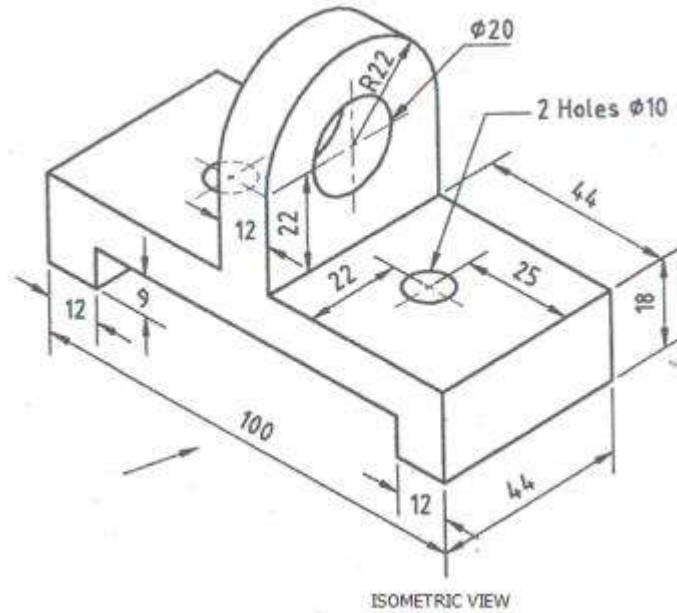

CO6

1. Design a simple pen stand for your study table and draw the three orthographic views of the product using AutoCAD software, following the ISO standards of Engineering drawing and print it on A4 size paper and submit your design.
2. Design a small ornament box and draw the three orthographic views of the product using AutoCAD software, following the ISO standards of Engineering drawing and print it on A4 size paper and submit your design.

<b>24ESL207</b>	<b>MANUFACTURING PRACTICES</b>	<b>L</b>	<b>T</b>	<b>P</b>	<b>J</b>	<b>S</b>	<b>C</b>	<b>Year of Introduction</b>
		<b>0</b>	<b>0</b>	<b>4</b>	<b>0</b>	<b>4</b>	<b>2</b>	<b>2024</b>

**Preamble:**To enable the student to familiarize various tools, measuring devices, practices and different methods of manufacturing processes employed in industry for fabricating components. Topics that give exposure to the hands-on experience on various basic engineering practices in Mechanical, Electrical and Electronics Engineering are included. This helps the learners to apply this experience while developing product/project for the benefit of society.

**Prerequisite:** NIL

**Course Outcomes:** After the completion of the course the student will be able to

<b>CO1</b>	Identify different manufacturing processes which are commonly employed in the industry to fabricate components [Understand level]
<b>CO2</b>	Use appropriate tools and instruments with respect to the mechanical workshop trades and fabricate components as per the design [Apply level]
<b>CO3</b>	Identify the tools used for electrical wiring, accessories, wires, cables, batteries and standard symbols. Execute wiring for simple circuits. [Understand level]
<b>CO4</b>	Develop the schematics and execute simple wiring circuits for domestic buildings. (Apply level)
<b>CO5</b>	Identify and test various electronic components. Fabricate electronic circuits on printed circuit boards and its testing. [Understand level]

**CO - PO MAPPING**

<b>CO</b>	<b>PO1</b>	<b>PO2</b>	<b>PO3</b>	<b>PO4</b>	<b>PO5</b>	<b>PO6</b>	<b>PO7</b>	<b>PO8</b>	<b>PO9</b>	<b>PO10</b>	<b>PO11</b>	<b>PO12</b>
<b>CO1</b>	✓	✓										
<b>CO2</b>	✓	✓							✓	✓		✓
<b>CO3</b>	✓	✓							✓	✓		✓
<b>CO4</b>	✓								✓	✓		✓
<b>CO5</b>	✓								✓	✓		✓

**Assessment Pattern**

<b>Bloom's Category</b>	<b>Continuous Assessment Tools</b>	
	<b>Class work</b>	<b>Test1</b>
Remember		
Understand	✓	✓
Apply	✓	✓
Analyse	✓	✓
Evaluate	✓	
Create	✓	



<b>Mark Distribution of CIA</b>				
<b>Course Structure [L-T-P-J]</b>	<b>Attendance</b>	<b>Class work</b>	<b>Lab Exam</b>	<b>Total Marks</b>
<b>0-0-4-0</b>	5	55	40	<b>100</b>
<b>Total Mark distribution</b>				
<b>Total Marks</b>	<b>CIA (Marks)</b>	<b>ESE (Marks)</b>	<b>ESE Duration</b>	
	100	0	-	

<b>SYLLABUS- DETAILS OF EXPERIMENTS</b>
<ul style="list-style-type: none"> <li>• Manufacturing Methods- Moulding and casting, and sheet metal</li> <li>• Conventional Machining (turning, drilling and shaping), CNC Machining</li> <li>• Fitting operations, Welding (Arc, gas and brazing)</li> <li>• Carpentry &amp; power tools, Plumbing, Plastic moulding and glass cutting</li> <li>• Electrical engineering - Study of tools, accessories and safety rules, batteries and earthing, Electrical machines and Transformer. Wiring exercises for simple circuits</li> <li>• Electronics Engineering – Study of electronic components, instruments, testing of electronic devices. Soldering exercises on PCB and electronic circuits</li> </ul>
<p><b>Text books</b></p> <ol style="list-style-type: none"> <li>1. Veerana D. K., Workshop / Manufacturing Practices, ISBN 9391505333</li> <li>2. Robert L.Boylestad’ “ Electronic Devices and Circuit Theory”, Prentice Hall of India, 2007</li> <li>3. D C Kulshreshtha, “Basic Electrical Engineering”, Tata McGraw Hill, 2010</li> </ol>
<p><b>Reference books</b></p> <ol style="list-style-type: none"> <li>1. Hajra Choudhury S.K., Hajra Choudhury A.K. and Nirjhar Roy S.K., “Elements of Workshop Technology”, Vol. I 2008 and Vol. II 2010, Media promoters and publishers private limited, Mumbai.</li> <li>2. Kalpakjian S. And Steven S. Schmid, “Manufacturing Engineering and Technology”, 4<sup>th</sup> edition, Pearson Education India Edition, 2002.</li> <li>3. Gowri P. Hariharan and A. Suresh Babu,” Manufacturing Technology – I” Pearson Education, 2008.</li> <li>4. Roy A. Lindberg, “Processes and Materials of Manufacture”, 4<sup>th</sup> edition, Prentice Hall India, 1998.</li> <li>5. Rao P.N., “Manufacturing Technology”, Vol. I and Vol. II, Tata McGraw Hill House, 2017.</li> <li>6. <a href="https://archive.nptel.ac.in/courses/112/107/112107219/mooc">https://archive.nptel.ac.in/courses/112/107/112107219/mooc</a></li> <li>7. Bernard Grob, “Basic Electronics”, Tata McGraw Hill, 2000</li> </ol>

## LIST OF EXPERIMENTS

<b>Mechanical -- 24 Hrs</b>	
<b>No.</b>	<b>Experiments</b>
1	Study and Exercise on foundry. Preparation of mould and making the cast of a given component
2	Study and Exercise on sheet metal. Make the box/can/tray with metal sheet as per the design
3	Study and Exercise on fitting and joining. Prepare the joints and weld together as per the drawing
4	Study and Exercise on Machining Prepare the model as per the drawing using turning, shaping and drilling operations.
5	Study and Exercise on Carpentry. Make simple wooden products like box, rack, etc using power tools.
6	Study and Exercise on plumbing. Do the pipeline assembly as per the sketch
7	Study on CNC Machine, Injection moulding machine, Glass cutting (Demo only)
8	Study on Electric devices and wiring. Exercise on simple wiring for lighting, fan, etc as per the design
9	Study on electronic components and soldering. Exercise on soldering the PCB and circuits as per the given design.

<b>ELECTRICAL WORKSHOP -12 Hrs</b>	
1	<ul style="list-style-type: none"><li>• Introduction to the precautionary steps adopted for Electrical shocks.</li><li>• Identify the Tools used for Electrical Wiring</li><li>• Study of Electrical Circuit Symbols and familiarization of wiring Accessories.</li></ul>
2	Prepare an estimate and Wire-up: A circuit having one light and fan point.
3	Prepare an estimate and Wire-up: A light/fan circuit using two-way switches. (Staircase wiring)
4	Prepare an estimate and Wire-up: A circuit having fluorescent lamp and socket outlet (6A).
5	Prepare an estimate and Wire-up: A Distribution board with one light point and one power outlet (16A) as sub circuits.
6	<ul style="list-style-type: none"><li>i) Demonstration of inverter wiring</li><li>ii) Demonstration of Earthing Schemes.</li><li>iii) Demonstration of Earth resistance measurement using equipment.</li></ul>

<b>ELECTRONICS WORKSHOP -12 Hrs</b>	
1	Familiarization and identification of active and passive electronic components (Resistor, Capacitor, Inductor, diode, transistor, sensing

	<p>elements, transformer)</p> <ul style="list-style-type: none"> <li>• Calculation of values, Usage of Data Sheets to find various specifications of Components.</li> </ul>
2	<p>Familiarization of Electronic Equipments (Fixed and Variable Power Supply, Function Generator, CRO, Ammeter, Voltmeter etc.)</p> <ul style="list-style-type: none"> <li>• Generation of Periodic waveforms using function generator and measuring various parameters. (Peak Value, Peak to Peak Value, RMS Value, Frequency etc.)</li> <li>• Testing of Diode and Transistors</li> <li>• Measurement of Current and Voltage in Series and Parallel resistor</li> </ul>
3	<p>Implementation of Circuits in bread board</p> <ul style="list-style-type: none"> <li>• Connecting LED from supply (Application of Resistor).</li> <li>• LED Connection using capacitor (Charge Storage application of Capacitor).</li> <li>• Application of Sensing Element (LDR).</li> <li>• Full wave Bridge Rectifier Circuit</li> </ul>
4	<p>Soldering Practice</p> <ul style="list-style-type: none"> <li>• Full Wave Bridge Rectifier</li> </ul>
5	<p>Introduction to Electronic Simulation tools- LT SPICE</p> <ul style="list-style-type: none"> <li>• Voltage and current through Series and Parallel passive components for AC and DC inputs.</li> <li>• Simulation of rectifier circuits.</li> </ul>

<b>CO Assessment Questions</b>	
1	Identify the best suitable manufacturing processes for a given product/design
2	A team work to fabricate the component as per the given design using available manufacturing methods and submit the report
3	Identify the components in the electric system shown in the drawing and complete the wiring as per the drawing to get the required result
4	Identify the electronic components in the given figure and assemble the component on a circuit board to enable the required function

24MCT210	SPORTS AND WELLNESS	L	T	P	J	S	C	Year of Introduction 2024
		2	0	0	0	2	1	

**Preamble:** Sports and wellness enable the students

- To understand the importance of sound health fitness principles as they relate to better health.
- To expose the students to a variety of physical and yogic activities aimed at stimulating their continued inquiry about Yoga, physical education, health and fitness.
- To create a safe, progressive, methodical and efficient activity-based plan to enhance improvement and minimize risk of injury.
- To develop among students an appreciation of physical activity as a lifetime pursuit and a means to better health.

**Prerequisite:**

**Course Outcomes:** After the completion of the course the student will be able to

<b>CO 1</b>	Explain health related fitness components: cardio respiratory endurance, flexibility and body composition etc.
<b>CO 2</b>	Apply first aid in real situation.
<b>CO 3</b>	Apply physiological principles related to exercise and training.
<b>CO 4</b>	Identify opportunities for participation in sports and games activities.
<b>CO 5</b>	Practice physical activities and yoga for flexibility, relaxation and quality life style.

**CO - PO MAPPING**

CO	PO1	PO2	PO3	PO4	PO5	PO6	PO7	PO8	PO9	PO10	PO11	PO12
<b>CO 1</b>								<b>3</b>	<b>3</b>	<b>3</b>		<b>3</b>
<b>CO 2</b>								<b>3</b>	<b>3</b>	<b>3</b>		<b>3</b>
<b>CO 3</b>								<b>3</b>	<b>3</b>	<b>3</b>		<b>3</b>
<b>CO 4</b>								<b>3</b>	<b>3</b>	<b>3</b>		<b>3</b>
<b>CO 5</b>								<b>3</b>	<b>3</b>	<b>3</b>		<b>3</b>

**Assessment Pattern**

Bloom's Category	Continuous Assessment Tools			End Semester Examination
	Test1	Test 2	Other tools	
Remember	✓	✓	✓	✓
Understand	✓	✓	✓	✓
Apply	✓	✓	✓	✓
Analyse			✓	
Evaluate				
Create				

<b>Mark Distribution of CIA</b>					
<b>Course Structure [L-T-P-J]</b>	<b>Attendance</b>	<b>Theory [L- T]</b>			<b>Total Marks</b>
		<b>Assignment</b>	<b>Test-1</b>	<b>Test-2</b>	
<b>2-0-0-0</b>	5	35	30	30	<b>100</b>
<b>Total Mark distribution</b>					
<b>Total Marks</b>	<b>CIA (Marks)</b>	<b>ESE (Marks)</b>		<b>ESE Duration</b>	
100	100	0		0	
<b>SYLLABUS</b>					
<b>MODULE I: Physical fitness, wellness and exercise programmes.</b>					
<ul style="list-style-type: none"> <li>• Meaning and importance of physical fitness and wellness.</li> <li>• Components of health-related fitness and sports related fitness</li> <li>• How to start an exercise programme.</li> <li>• How to select proper exercises.</li> <li>• Exercise for improving speed, strength, endurance, and flexibility and co ordinative abilities.</li> <li>• Exercises to prevent back pain, tennis elbow, shoulder injury and knee pain, neck pain.</li> <li>• Fitness test for health-related fitness components.</li> <li>• Importance of weight training.</li> <li>• Importance of warming up and cooling down.</li> <li>• How to deal with every day stress.</li> </ul>					
<b>MODULE II : First aid</b>					
<ul style="list-style-type: none"> <li>• First aid and principles of first aid</li> <li>• First aid measure for the following – Bleeding through Nose, Snakebite, Dog Bite, Electric Shock, Burns and Drowning</li> <li>• Common injuries and their management Wounds, Cuts, Sprain, Strain, Fracture and Dislocation.</li> <li>• Cardio pulmonary resuscitation. (CPR)</li> <li>• How to prevent muscle cramps and its management.</li> <li>• How to carry an injured person.</li> </ul>					
<b>MODULE III: Fundamentals of Anatomy and physiology in physical education and Postures.</b>					
<ul style="list-style-type: none"> <li>• Define Anatomy, physiology and its importance.</li> </ul>					

- Effects of exercise on the functioning of various body system (Cardio respiratory system, muscular system and digestive system)
- Posture and its importance.
- Common Postural Deformities-Knock Knee; Flat Foot; Round Shoulders; Lordosis, Kyphosis, Bow Legs and Scoliosis.
- Corrective Measures for Postural Deformities.
- Exercise and happy hormones.
- Substance abuse.

#### **MODULE IV : Sports and games**

- Following subtopics related to anyone game/sport of choice of student out of Football, Shuttle badminton, Volleyball, Basketball, Tennis and cricket
  - Specification of play fields and related sports equipments
  - Sports and games for recreation.
- Latest general rule of the game / sports.

#### **MODULE V : Lifestyle & Yoga**

- Balanced diet, mal nutrition and Deficiency disease.
- Healthy diet plan.
- Hydration and its importance.
- Personal hygiene.
- Rest and recovery.
- Importance of sleep.
- Meaning & importance of Yoga.
- Introduction-Asanas, Pranayama, Meditation.
- Relaxation Techniques in yoga
- Asanas to prevent life style disease.

#### **Text books**

1. Modern Trends and Physical Education by Prof. Ajmer Singh.
2. Light on Yoga by B.K.S. Iyengar.
3. Health and Physical Education- NCERT (11th and 12th Classes)

#### **Reference books**

1. Physiological aspects of sports training and performance by Jay Hoffman.
2. Periodization theory and methodology of training by Tudor O Bompa and G Grisgery Haff.
3. Essential of strength training and conditioning by Thomas Baechle E R, Roger W Earle.
4. A practice guide to emergency first aid, safety injuries, illnesses by Montreal.

<b>COURSE CONTENTS AND LECTURE SCHEDULE</b>		
No.		No. of Hours[24[
<b>MODULE 1: Physical fitness, wellness and exercise programmes.</b>		
1.1	<ul style="list-style-type: none"> <li>• Meaning and importance of physical fitness and wellness.</li> <li>• Components of health-related fitness and sports related fitness.</li> </ul>	1
1.2	<ul style="list-style-type: none"> <li>• How to start an exercise programme.</li> <li>• Exercise for improving speed, strength, endurance, and flexibility and co ordinative abilities.</li> <li>• How to select proper exercises.</li> </ul>	1
1.3	<ul style="list-style-type: none"> <li>• Exercises to prevent back pain, tennis elbow, shoulder injury and knee pain, Neck pain.</li> </ul>	1
1.4	<ul style="list-style-type: none"> <li>• Fitness test for health-related fitness components.</li> </ul>	1
1.5	<ul style="list-style-type: none"> <li>• Importance of weight training.</li> <li>• Importance of warming up and cooling down.</li> </ul>	1
1.6	<ul style="list-style-type: none"> <li>• How to deal with every day stress.</li> </ul>	1
<b>MODULE II: First aid</b>		
2.1	<ul style="list-style-type: none"> <li>• First aid and principles of first aid</li> <li>• First aid measure for the following – Bleeding through Nose, Snakebite, Dog Bite, Electric Shock, Burns and Drowning.</li> </ul>	1
2.4	<ul style="list-style-type: none"> <li>• Common injuries and their management Wounds, Cuts, Sprain, Strain, Fracture and Dislocation.</li> </ul>	1
2.5	<ul style="list-style-type: none"> <li>• Cardio pulmonary resuscitation. (CPR)</li> </ul>	1
2.6	<ul style="list-style-type: none"> <li>• How to prevent muscle cramps and its management.</li> <li>• How to carry an injured person</li> </ul>	1
<b>MODULE III: Fundamentals of Anatomy and physiology in physical education and Postures.</b>		
3.1	<ul style="list-style-type: none"> <li>• Define Anatomy, physiology and its importance.</li> <li>• Effects of exercise on the functioning of various body system (Cardio respiratory system, muscular system and digestive system)</li> </ul>	1
3.2	<ul style="list-style-type: none"> <li>• Posture and its importance.</li> </ul>	1
3.3	<ul style="list-style-type: none"> <li>• Common Postural Deformities-Knock Knee; Flat Foot; Round Shoulders; Lordosis, Kyphosis, Bow Legs and Scoliosis.</li> <li>• Corrective Measures for Postural Deformities.</li> </ul>	1

3.4	<ul style="list-style-type: none"> <li>• Exercise and happy hormones.</li> <li>• Substance abuse.</li> </ul>	1
<b>MODULE IV: Sports and games.</b>		
4.1	Football	1
4.2	Shuttle badminton	1
4.3	Volleyball	1
4.4	Basketball	1
4.5	Cricket	1
4.6	Tennis <ul style="list-style-type: none"> <li>• Sports and games for recreation.</li> <li>• Latest general rule of the game / sports.</li> <li>• Specification of play fields and related sports equipment</li> </ul>	1
<b>Module 5- Lifestyle &amp; Yoga</b>		
5.1	<ul style="list-style-type: none"> <li>• Balanced diet, mal nutrition and Deficiency disease.</li> <li>• Healthy diet plan</li> <li>• Hydration and its importance.</li> </ul>	1
5.2	<ul style="list-style-type: none"> <li>• Personal hygiene.</li> <li>• Rest and recovery.</li> <li>• Importance of sleep.</li> </ul>	1
5.3	<ul style="list-style-type: none"> <li>• Meaning &amp; importance of Yoga.</li> <li>• Introduction-Asanas, Pranayama, Meditation.</li> </ul>	1
5.4	<ul style="list-style-type: none"> <li>• Relaxation techniques in yoga.</li> <li>• Asanas to prevent life style disease.</li> </ul>	1

<b>CO Assessment Questions</b>	
1	What are the types of Asanas for improving strength and flexibilities?
2	What are the physiological changes to cardio respiratory system during exercise?
3	What are the first aid to sprains and strains?
4	How to develop cardio respiratory fitness?
5	Which are the seventeen laws in football?
6	Which are the exercises to prevent back and shoulder pain?



<b>24HUT211</b>	<b>Universal Human Values-II</b>	<b>L</b>	<b>T</b>	<b>P</b>	<b>J</b>	<b>S</b>	<b>C</b>	<b>Year of Introduction</b>
		<b>2</b>	<b>1</b>	<b>0</b>	<b>0</b>	<b>2</b>	<b>3</b>	<b>2024</b>

**Preamble:** This course helps the students to appreciate the essential complementarity between 'VALUES' and 'SKILLS' to ensure sustained happiness and prosperity which are the core aspirations of all human beings. The topics covered in this course are the concepts of self exploration, values and skills, happiness and prosperity, harmony in family and society, harmony in the nature and society, and ethical values needed for the life and profession of an individual. This course enables the learners to develop a holistic perspective towards life and profession & towards happiness and prosperity based on a correct understanding of the human reality and the rest of existence.

**Prerequisite: Universal Human Values I (Student Induction Program)**

**Course Outcomes:** After the completion of the course the student will be able to

<b>CO1</b>	Evaluate the significance of value inputs in formal education and start applying them in their life and profession. [Apply level]
<b>CO2</b>	Distinguish between values and skills, happiness and accumulation of physical facilities, the Self and the Body, Intention and Competence of an individual. [Analyze level]
<b>CO3</b>	Demonstrate the value of harmonious relationship based on trust and respect in their life and profession. [Analyze level]
<b>CO4</b>	Examine the role of a human being in ensuring harmony in society and nature. [Analyze level]
<b>CO5</b>	Use the understanding of ethical conduct to formulate the strategy for ethical life and profession. [Apply level]

**CO - PO MAPPING**

<b>CO</b>	<b>PO1</b>	<b>PO2</b>	<b>PO3</b>	<b>PO4</b>	<b>PO5</b>	<b>PO6</b>	<b>PO7</b>	<b>PO8</b>	<b>PO9</b>	<b>PO10</b>	<b>PO11</b>	<b>PO12</b>
<b>CO1</b>						✓	✓	✓	✓	✓		✓
<b>CO2</b>						✓	✓	✓	✓	✓		✓
<b>CO3</b>						✓	✓	✓	✓	✓		✓
<b>CO4</b>						✓	✓	✓	✓	✓		✓
<b>CO5</b>						✓	✓	✓	✓	✓		✓

**Assessment Pattern**

<b>Bloom's Category</b>	<b>Continuous Assessment Tools</b>			<b>End Semester Examination</b>
	<b>Test1</b>	<b>Test 2</b>	<b>Other tools</b>	
Remember	✓	✓	✓	✓
Understand	✓	✓	✓	✓
Apply	✓	✓	✓	✓
Analyse				
Evaluate				
Create				

<b>Mark Distribution of CIA</b>					
<b>Course Structure [L-T-P-J]</b>	<b>Attendance</b>	<b>Theory [L- T]</b>			<b>Total Marks</b>
		<b>Assignment</b>	<b>Test-1</b>	<b>Test-2</b>	
<b>2-1-0-0</b>	5	15	10	10	<b>40</b>
<b>Total Mark distribution</b>					
<b>Total Marks</b>	<b>CIA (Marks)</b>	<b>ESE (Marks)</b>		<b>ESE Duration</b>	
100	40	60		3 hours	
<b>End Semester Examination [ESE]: Pattern</b>					
<b>PATTERN</b>	<b>PART A</b>	<b>PART B</b>			<b>ESE Marks</b>
PATTERN 1	10 Questions, each question carries 2 marks	2 questions will be given from each module, out of which 1 question should be answered. Each question can have a maximum of 2 sub divisions. Each question carries 8 marks.			60
	Marks: (2x10 =20 marks)	Marks: (5x8 = 40 marks) Time: 3 hours			
	Total Marks: 20	Total Marks: [5x8 = 40 marks]			
<b>SYLLABUS</b>					
<b>MODULE I : Introduction to Value Education</b>					
Right Understanding, Relationship and Physical Facility (Holistic Development and the Role of Education), Understanding Value Education, Self-exploration as the Process for Value Education, Continuous Happiness and Prosperity – the Basic Human Aspirations, Happiness and Prosperity – Current Scenario, Method to Fulfill the Basic Human Aspirations.					
<b>MODULE II : Harmony in the Human Being</b>					
Understanding Human being as the Co-existence of the Self and the Body, distinguishing between the Needs of the Self and the Body, The Body as an Instrument of the Self, Understanding Harmony in the Self, Harmony of the Self with the Body, Programme to ensure self-regulation and Health.					
<b>MODULE III : Harmony in the Family and Society</b>					
Harmony in the Family – the Basic Unit of Human Interaction, 'Trust' – the Foundational Value in Relationship, 'Respect' – as the Right Evaluation, Other Feelings, Justice in Human-to-Human Relationship, Understanding Harmony in the Society, Vision for the Universal Human Order.					
<b>MODULE IV: Harmony in the Nature/Existence</b>					
Understanding Harmony in the Nature, Interconnectedness, self-regulation and Mutual Fulfillment among the Four Orders of Nature, Realizing Existence as Co-existence at All Levels, Holistic Perception of Harmony in Existence.					

**MODULE V: Implications of the Holistic Understanding – a Look at Professional Ethics**

Natural Acceptance of Human Values, Definitiveness of (Ethical) Human Conduct, A Basis for Humanistic Education, Humanistic Constitution and Universal Human Order, Competence in Professional Ethics, Holistic Technologies, Production Systems and Management Models- Typical, Strategies for Transition towards Value-based Life and Profession.

**Text books**

1. A Foundation Course in Human Values and Professional Ethics, R R Gaur, R Asthana, G P Bagaria, 2nd Revised Edition, Excel Books, New Delhi, 2019. ISBN 978-93-87034-47-1
2. Teachers’ Manual for A Foundation Course in Human Values and Professional Ethics, RR Gaur, R Asthana, G P Bagaria, 2nd Revised Edition, Excel Books, New Delhi, 2019.

**Reference books**

1. JeevanVidya: EkParichaya, A Nagaraj, JeevanVidyaPrakashan, Amarkantak, 1999.
2. Human Values, A.N. Tripathi, New Age Intl. Publishers, New Delhi, 2004.
3. The Story of Stuff (Book). Annie Leonard, Publisher: Free Press (February 22, 2011), ISBN13: 9781451610291
4. The Story of My Experiments with Truth - by Mohandas Karamchand Gandhi

**COURSE CONTENTS AND LECTURE SCHEDULE**

No.		No. of Hours [36 ]
<b>MODULE 1</b>		
1.1	Understanding Value Education	1
1.2	Tutorial 1- Sharing about Oneself	1
1.3	Self-exploration as the Process for Value Education	1
1.4	Continuous Happiness and Prosperity – the Basic Human Aspirations	1
1.5	Tutorial 2 - Exploring Human Consciousness	1
1.6	Happiness and Prosperity – Current Scenario	1
1.7	Method to Fulfill the Basic Human Aspirations	1
1.8	Tutorial 3 - Exploring Natural Acceptance	1
<b>MODULE II</b>		
2.1	Understanding Human being as the Co-existence of the Self and the Body	1
2.2	Distinguishing between the Needs of the Self and the Body	1
2.3	Tutorial 1 - Exploring the difference of Needs of Self and Body	1
2.4	The Body as an Instrument of the Self and Understanding Harmony in the Self	1
2.5	Tutorial 2 - Exploring Sources of Imagination in the Self	1

2.6	Harmony of the Self with the Body	1
2.7	Programme to ensure self-regulation and Health	1
2.8	Tutorial 3 - Exploring Harmony of Self with the Body	1
<b>MODULE III</b>		
3.1	Harmony in the Family – the Basic Unit of Human Interaction	1
3.2	'Trust' – the Foundational Value in Relationship	1
3.3	Tutorial 1 - Exploring the Feeling of Trust	1
3.4	'Respect' – as the Right Evaluation	1
3.5	Tutorial 2 - Exploring the Feeling of Respect	1
3.6	Other Feelings, Justice in Human-to-Human Relationship	1
3.7	Understanding Harmony in the Society and Vision for the Universal Human Order	1
3.8	Tutorial 3 - Exploring Systems to fulfill Human Goal	1
<b>MODULE IV</b>		
4.1	Understanding Harmony in the Nature, Interconnectedness, self-regulation and Mutual Fulfillment among the Four Orders of Nature	1
4.2	Tutorial 1 - Exploring the Four Orders of Nature	1
4.3	Realizing Existence as Co-existence at All Levels	1
4.4	The Holistic Perception of Harmony in Existence	1
4.5	Tutorial 2 - Exploring Co-existence in Existence	1
<b>MODULE V</b>		
5.1	Natural Acceptance of Human Values, Definitiveness of (Ethical) Human Conduct	1
5.2	Exploring Ethical Human Conduct	1
5.3	A Basis for Humanistic Education, Humanistic Constitution and Universal Human Order, Professional Ethics	1
5.4	Exploring Humanistic Models in Education	1
5.5	Holistic Technologies, Production Systems and Management Models-Typical Case Studies	1
5.6	Strategies for Transition towards Value-based Life and Profession	1
5.7	Exploring Steps of Transition towards Universal Human Order	1

<b>CO Assessment Questions</b>	
1	<ol style="list-style-type: none"> <li>1. What does a fulfilling life mean for you? List out the top five points that occur to you when you think of a fulfilling life. While making the list, please consider your entire life, not just the present stage of your life (youth, middle age, old age, etc.).</li> <li>2. Choose any five things that you consider as human values. Now write all the basic guidelines, and check if you they satisfy the basic guidelines.</li> </ol>

(Hint: Someone may say Trust is a human value. Now check if it satisfies the basic guidelines.)

3. List your activities throughout a typical day in your life. Categorize these activities as activity for developing right understanding, activity for fulfillment in relationship and activity for physical facility (see table, below).

Activity	This activity has time and effort for		
	Right understanding	Fulfillment in relationship	Physical facility
Exercise, playing games (2 hrs/day)	?	?	2 hrs (for health of body)
Talking with friends	?	3 hrs (for relationship)	?
Studying	1 hr (studying for values)	?	6 hrs (studying for skills)

Sleeping

This is just a sample list. Please make your own list

Total Time and Effort

Max 24 hrs

Find out what percentage of your time and effort is being spent for each of these three. What do you conclude from this exercise?

Find out if the following are naturally acceptable to you.

Statement	My present thinking (beliefs) about the statement	Naturally Acceptable?
I want to be happy		
I want to make others happy		
I want to be healthy		
I want to live in relationship		
I want to have more than others		
I want to have more than what I really need		
Feeling of respect in relationship	Only if you have money, people respect you	Feeling of respect is naturally acceptable in relationship

2

Can you observe that when you really try, you can refer to your natural acceptance? Note any five things that appear naturally acceptable to you. Now, verify for yourself that your 'natural acceptance' does not change with time or place. It does not depend on your beliefs and past conditionings and that it is always there. If not, would you still call it your natural acceptance? And if not, what can it be termed as in place of natural

	<p>acceptance? e.g., eating sweets. It may appear naturally acceptable. Now explore, whether it changes with time, place and individual or not. You will see that sometimes you like eating sweets, while sometimes; you do not feel like eating sweets. Same thing happens with place. And not everyone wants to eat sweets. Thus, it does not fulfill the criterion. It is not your 'natural acceptance'. Then what is your natural acceptance? Find it out (here, while eating sweets is your liking, nurturing your Body is the natural acceptance).</p>
3	<ol style="list-style-type: none"> <li>1. "The pleasures that we derive from sensations are short lived and the efforts to extend them lead to misery" -Examine and illustrate this statement with an example.</li> <li>2. Explain the activities of imaging, analyzing and selecting/tasting with a diagram. With the help of an example, show how are they related.</li> <li>3. "If I trust everyone, people would take undue advantage of me." Do you agree? Explain.</li> <li>4. "When we are assured of the intention of the other and find that the competence is lacking, we become a help to the other. When we doubt the intention of the other, we get into opposition." Explain.</li> </ol>
4	<ol style="list-style-type: none"> <li>1. What in your opinion, is an effective way of ensuring prosperity in the family? What programs can you undertake in this respect?</li> <li>2. Indicate a few feasible steps to promote harmony in the society and co-existence with nature.</li> <li>3. "Other than human order, the three orders are mutually fulfilling to each other." Explain with examples. Why does human order fail to be mutually fulfilling to itself and to the other orders?</li> </ol>
5	<ol style="list-style-type: none"> <li>1. How does right understanding provide the basis for ethical human conduct? Give two examples.</li> <li>2. What are the values in interaction of human beings with the material things? Give one example of each.</li> <li>3. Visualize a framework for humanistic education for children. Suggest a few ways to modify present day school education.</li> <li>4. Choose any one dimension (education, health, production, justice, exchange) of human endeavor in a society. Suggest what role can you play in the chosen dimension through the orientation you are going to have through your professional education.</li> </ol>